

TABLE OF CONTENTS, D10010 and AD5020 SERVO AMPLIFIER

SECTION	TITLE	PAGE
1.00	Introduction and Description.....	2
2.00	Theory of Operation.....	3
3.00	Adjustments.....	4
3.11	IR COMP.....	4
3.12	VLP TIME CONSTANT.....	4
3.13	VLP AC GAIN.....	4
3.14	ILP TIME CONSTANT.....	4
3.15	HI TACH.....	4
3.16	VLP or ILP selector.....	5
3.17	VFB VOLTAGE RANGE.....	5
3.18	ZERO.....	5
3.19	GAIN.....	5
3.30	Factory Adjustments.....	5
4.00	Wiring Instructions.....	6
4.10	CONTROL WIRING.....	6
4.11	INPUT COMMAND REFERENCE.....	6
4.12	TACH FEEDBACK.....	6
4.13	EMF FEEDBACK.....	7
4.14	CURRENT FEEDBACK (Current Loop).....	7
4.15	DISABLE INPUTS.....	7
4.16	+5V AND -5V.....	7
4.17	STATUS, AOK.....	7
4.20	POWER WIRING.....	8
5.00	Specifications.....	9
5.10	INSTALLATION MECHANICAL.....	9
5.20	ELECTRICAL SPECIFICATIONS (Control).....	9
5.30	ELECTRICAL SPECIFICATIONS (Power).....	9
5.40	OPERATIONAL MODES.....	10
5.50	STATUS.....	10
5.60	RESPONSE TIME.....	10
6.00	Setup Instructions.....	11
6.10	SETUP FOR EMF AND TACH FEEDBACK.....	11
6.20	SETUP FOR CURRENT LOOP.....	12
6.30	SETUP FOR CONTROLLING CURRENT LIMIT (PIN 11)....	13
7.00	FIGURES 1-6.....	14

1.0 Introduction and Description

The AD5020 is a high performance servo amplifier that drives high performance DC Servo Motors. It is a compact, self contained unit with its own power supply, input and output power filters and regeneration circuit. Power to the unit is from a power transformer or, a DC supply, or a battery.

The AD5020 is different from other servo amplifiers in that it drives the motor with essentially pure DC instead of pulses. Faster response can be achieved because the switching frequency is exactly 125 KHz, which is 6 to 12 times faster than competitive servos.

Nearly perfect isolation is achieved from the control inputs to the motor circuit by the use of Hall sensors and opto couplers. Hall sensors are used to sense the motor current and high speed opto couplers are used to control the power MOS FETs. A power clamp protects against excessive regeneration when frequent high speed or high inertia reversals occur.

System control can be either speed loop or torque loop, with or without tachometer. IR compensation is available for stiffer control when a tachometer is not used. Compensation for the current loop, the speed loop, and feedback input is implemented by adjusting 10 position rotary switches. This assures stability of settings, predictable changes, and repeatability from unit to unit.

Unlike other servos the AD5020 switches only one Power MOS FET at a time resulting in less power dissipation and less ripple. In addition the output is filtered to DC which virtually eliminates EMI-RFI at the motor.

The Disable inputs are unique in that they immediately inhibit the motor direction by clamping the reference internally to a near zero speed but allow braking of the motor so that it can be stopped abruptly.

The case temperature of the AD5020 is monitored and in the event of a motor stall or overload, current to the motor is reduced automatically to hold the transistor temperatures to a safe level. A corresponding red LED turns on and contacts of a relay open to signal the host controller.

Separate +5V and -5V regulators are available to the user when a Potentiometer is used for the speed or current reference.

2.0 Theory of Operation

2.1 Block Diagram.

Refer to Figure 1. A tachometer or EMF of the motor is connected to terminals 6 and 5 of the control plug. The reference signal, either speed loop or current loop, is connected to terminals 2 and 3 of the control plug. These two signals are summed, and compensated and become the current reference of the system. The current feedback comes from the Hall Sensor which senses actual motor current, and is summed with the afore mentioned current reference and is compensated. This signal essentially controls the on time of the pulse width modulator inside the "Proprietary Circuitry".

This circuit generates 4 gate drive signals, which are either on or off, that completely control the H Bridge in the lower part of the diagram. A crystal controlled oscillator is used to generate the saw tooth type waveforms that are needed in pulse width modulation. Two inhibit lines control the H Bridge so that the torque of the motor is restricted in either direction or both when an outside Disable signal is present.

The power plug is connected to either AC or DC to make a DC bus (12-50V) that the H Bridge switches. This Power input is heavily filtered so that EMI-RFI does not get back to the power source. The left and right side of the H Bridge is filtered before going out to the motor terminals 1 and 2.

Because the switching frequency is high and the peak to peak output of the bridge is the amplitude of the bus (max 50V) and not double the bus (100V), filtering the output of the bridge is practical and effective. The ripple voltage out of the motor plug, terminals 1 and 2, becomes negligible.

A thermistor is attached to the Aluminum case to which the power transistors are mounted which gives a thermal feedback. When the case temperature reaches 60 Degrees Centigrade, the max allowed motor current is slowly reduced. This protects the servo amplifier from overheating when the motor is stalled or overloaded, or if the ambient temperature becomes too high.

3.0 Adjustments

3.11 IR COMP.

The IR compensation adjustments are shown in Figure 2. There is a selector header that allows IR COMP to be selected OUT or IN. If the selector is in the "IR" position, the POT labeled "IR/LD" will add some current signal to the EMF feedback that is present at terminals 5 and 6 of the control plug. The setting of this pot should be made when the motor is working at slow speed and the load to the motor can be changed. Adjust the POT so that the motor does not slow down when loaded. IF the motor is loaded too heavily during this procedure current limit will take over and the motor speed will drop. If the motor speed increases when loaded, too much IR COMP is being added.

3.12 VLP TIME CONSTANT.

This adjustment is a 10 position rotary switch that effectively allows 10 values of a capacitor that is configured in a lag network as shown in the left COMPENSATION box of Figure 1. Figure 3 shows the effect of this adjustment. Setting the arrow on this adjustment to the number 9 will introduce the maximum capacitance in the circuit and thus slow down the response time or time between overshoots. This adjustment has no effect when the VLP, ILP header is selected for ILP.

3.13 VLP AC GAIN.

This adjustment is a 10 position digital switch that effectively allows 10 values of a resistor that is configured in a lag network as shown in the left COMPENSATION box of Figure 1. Figure 3 shows the effect of this adjustment. Setting the arrow on this adjustment to the number 9 will introduce the minimum resistance in the circuit and thus reduce or eliminate overshoots. This adjustment affects the time constant of the loop and 3.12 above will have to be repeated. This adjustment has no effect when the VLP, ILP header is selected for ILP.

3.14 ILP TIME CONSTANT.

This adjustment is normally set at the factory. This 10 position rotary switch is found near the center of the top of the unit under the cover. This adjustment allows 10 values of a capacitor configured in a lag network as shown in the right COMPENSATION box of Figure 1. Figure 3 shows the effect of this adjustment. Setting the arrow on this adjustment to the number 9 will introduce the maximum capacitance into the circuit and thus slow down the response time or the time between overshoots.

3.15 HI TACH.

This adjustment is shown in Figure 2 and is part of the input scaling of the incoming tachometer voltage. This female jumper should be in the lower position for incoming voltages less than 50 volts. This jumper should be in the upper position for tach voltages between 50 and 100 volts. For EMF feedback, the female jumper should be in the lower position since the EMF voltage cannot exceed 50 volts.

3.16 VLP or ILP selector.

This adjustment is shown in Figure 2 and chooses whether the VREF input at terminals 2 and 3 of the control plug will control the voltage or current to the motor. With the female jumper in the upper position, current will be controlled. With the female jumper in the lower position, voltage will be controlled.

3.17 VFB VOLTAGE RANGE.

This adjustment is shown in Figure 2 and scales the feedback voltage coming in at terminals 5 and 6 of the control plug. Use the chart in Figure 2 or on the label of the unit to select the correct maximum input voltage. With the arrow of the switch set at 0, the maximum input voltage is 5 volts with the HI TACH jumper in the low position. Example: A 6.8 volt/1000RPM tach is used and the max speed is 2000 RPM, so the max voltage is 13.4 volts. The HI TACH jumper should be in the lower position and the VFB VOLTAGE RANGE switch should be pointing at the number "2".

3.18 ZERO

This adjustment is shown in Figure 2 and is intended to set the motor speed to zero, when in the "VLP" mode; and to set the motor current (speed) to zero, when in the "ILP" mode with the input reference voltage at terminals 2 and 3 of the control plug at 0 volts.

3.19 GAIN.

This adjustment is shown in Figure 2. With the input reference voltage at terminals 2 and 3 of the control plug set at the maximum level:

1. Set the maximum speed of the motor when in the "VLP" mode;
2. Set the maximum motor current, locked rotor, when in the "ILP" mode.

When in the "ILP" mode, the current level cannot be set higher than the current limit level.

3.30 FACTORY ADJUSTMENTS.

On the side opposite from the customer plug connections there are 4 factory adjustments. These are current limit, current offset, and 2 "power" pots that need a special set up to optimize their settings. These adjustments should only be set by authorized personnel. The current limit setting is set at standard levels or set at special settings when specified on the customer's Purchase Order.

The Disable inputs are pulled up to +12V internal to the AD5020, and these inputs have a threshold of 6 volts. These inputs can be pulled up to +5V with a threshold of 2.5V by changing a jumper inside the unit. Consult Factory for instructions.

4.00 Wiring Instructions.

4.10 Control Wiring.

The Control wiring consists of connecting low current carrying wires to the 12 terminal control plug located on the top left side of the unit. 22 gauge wire is adequate for all connections.

4.11 Input command reference.

Connections should be made with a shielded twisted pair with the shield connected at the signal source.

Refer to Figure 4. The input command reference, VREF+ and VREF-, is the input signal that controls the motor speed or motor current (torque). If the reference is a single ended signal, VREF-, terminal 3 of the control plug, should be tied to common. VREF+ should be tied to the signal source and the signal source common should be tied to terminal 1 or 4 of the control plug, which is the servo common.

If the input command reference is to interface with a differential output source, or has two inputs, the appropriate lines should be connected to the VREF+ and VREF- inputs. The signal source common should be tied to terminal 1 or 4 of the control plug, which is servo common.

If a Pot is used for controlling the motor speed or current as a stand alone system, the -5V and +5V, terminals 9 and 10 of the control plug may be used. For single direction control, connect +5V to one end of a 1000 --> 10000 ohm pot and the other end to common. Connect the wiper to either terminal 2 or 3 of the control plug, depending on what direction is desired. A (plus) + voltage at terminal 2 of the control plug will cause a (plus) + voltage at terminal 2 of the motor plug. Connect the unused terminal (2 or 3) to common.

If bidirectional control is desired, connect the Pot between the +5V and -5V. Do not draw more than 10ma out of either supply.

4.12 Tach feedback.

Connect the tachometer to the VFB+ and VFB- inputs, terminals 5 and 6 of the control plug. Connect terminal 5 also to common, terminal 1 or 4. The polarity key is that terminal 6 should be (plus) + when terminal 2 is (plus) +. Connections should be made with a shielded twisted pair with the shield connected at the tachometer source to the same wire that is connected to common.

4.13 EMF feedback.

Connect the MTR+, terminal 2 of the power plug to the VFB+ input of the control plug, terminal 6. Connect the MTR-, terminal 1 of the power plug to the VFB- input of the control plug, terminal 5. Do not connect either of these signals to common or earth ground. If long runs from the AD5020 to the motor are necessary, remote sensing can be used by running a separate pair of wires from the motor terminals to the VFB+ and VFB- terminals instead. Connections should be made with a shielded twisted pair with the shield connected to common at the AD5020 side.

4.14 Current feedback (Current loop).

Current feedback requires no connections to the VFB+ and VFB- inputs of the control plug, and should be left open. The current feedback is internal to the AD5020.

4.15 Disable inputs.

If the disable inputs are not to be used, connect terminals 7 and 8 to common.

If a single disable input is to inhibit the AD5020, connect terminals 7 and 8 to each other and to a normally closed contact to common. An open collector transistor can be used with the collector connected to terminals 7 and 8 of the control plug.

If both motor directions are to be disabled, connect terminal 7 to a normally closed contact to common. Connect terminal 8 to normally closed contact to common. Open collector transistors can be used with the collectors connected to terminals 7 and 8 separately. Terminal 7 disables the motor voltage from being (plus) + at terminal 2 of the power plug. See figure 4.

4.16 +5V and -5V

There are two regulated supplies, separate from the internal supplies of the AD5020 that are intended to be used for Potentiometer excitation. These supplies are short circuit proof. See Section 4.11.

4.17 Status, AOK

Terminals 11 and 12 of the control plug are connected to a normally closed relay contact that opens up if there is a problem. These terminals should be connected to the host supervisor for monitoring.

4.20 POWER WIRING. **DC10010 IS DC ONLY**

All power connections are made to the 6 pin power plug, located below the control plug. The AD50XX develops a DC BUS voltage from the AC power connection or by a direct DC connection, but not both. It is recommended that the DC BUS voltage be selected so that there is enough voltage to accelerate and run the motor, but limited so that if full voltage were applied, the motor would not be driven to excessive speeds.

Connect either AC to terminals 4 and 3 or a DC supply to terminals 5 and 6, but not both. For AC connections polarity need not be followed. For DC connections, terminal 5 is - and terminal 6 is +. Use the appropriate gauge wire, 12 ga for 20 amps, 14 ga for 15 amps, and 16 ga for 7 amps. If long runs are to be made voltage drop should be calculated and compensated for in gauge and voltage level.

Connect the motor to terminals 1 and 2. Use the appropriate gauge wire, 12 ga for 20 amps, 14 ga for 15 amps, and 16 ga for 7 amps. The polarity is such that terminal 2 will go positive (+) when a positive voltage is applied to terminal 2 (VREF+) of the control plug. The motor should cause a feedback such that terminal 6 (VFB) of the control plug is driven positive.

5.0 Specifications.

5.10 Installation Mechanical.

The mechanical dimensions of the AD5020 and the D10010 are shown in Figure 5. The unit fits into a box of 4.10" X 11.05" X 3.30" without the four mounting tabs in each corner. The 12 pin control plug is on the top right side of the unit and the 6 pin power plug is below it.

5.20 Electrical Specifications (Control).

Input resistances.

Terminal 1 and 4 are common (control plug).

Terminal 2, VREF+: 10k ohm to common with terminal 3 tied to common.
20k ohm with respect to terminal 3.

Terminal 3, VREF-: 20k ohm to common.

Terminal 6, VFB+: 50k ohm to common with terminal 5 tied to common.
100k ohm with respect to terminal 6.

Terminal 5, VFB-: 60k ohm to common.

Terminal 7, DISABLE+: 2.2k ohm pull up to +5V or +12V, depending on selector on board.

Terminal 8, DISABLE-: 2.2k ohm pull up to +5V or +12V, depending on selector on board.

<u>Switching Frequency:</u>	125 KHz, crystal controlled
<u>Form Factor:</u>	1.003 max at ½ current, ½ voltage
<u>Gain Range, velocity mode:</u>	.005 to 3 volt/volt
<u>Gain Range, current mode:</u>	AD5010, .66 to 50 amps/volt
<u>Offset:</u>	Adjustable to zero with ZERO Pot.
<u>Drift:</u>	.1%/Deg C, max
<u>VFB Input voltage range:</u>	5 to 100 volts
<u>VREF Input voltage range:</u>	1 to 10 volts
<u>STATUS:</u>	NC Contact, 100 V DC, 10 Watts reed relay

5.30 Electrical Specifications (Power).

Input Voltage, AC (AD5020): 10 to 35 Volts RMS, 1 Phase, 50/60 Hz

Input Voltage, DC: 12 to 50 Volts DC

Output Voltage: 0 to the DC Bus less 1.1 volt, bidirectional.

Continuous Output Current: AD5020: 20 amps

D10010: 10 amps

Thermal Time Constant: 12 minutes

5.40 Operational Modes.

1. Speed Loop with tachometer feedback.
2. Speed Loop with EMF feedback, without IR Compensation.
3. Speed Loop with EMF feedback, with IR Compensation.
4. Current (Torque) Loop.

5.50 Status

The Status of the AD5020 is conveyed by a normally closed contact available at terminals 11 and 12 of the control plug. The Status is also referred to as fault and "AOK". The red LED turns on and the contacts are opened if:

1. There is no power to the unit.
2. The internal power supplies have failed.
3. The AD5020 is in thermal limiting.

5.60 Response Time.

The response time of an AD5020 is shown in Figure 6. The input is a square wave driving a servo motor with tachometer. The time it took for the motor current to get to 50% of the maximum limit was 75 microseconds.

The best any servo amplifier can do is to deliver a certain limited current to the motor as fast as possible on demand. The AD5020 had only a 122 microsecond delay.

6.00 Setup Instructions.

6.10 Setup for EMF and Tach feedback.

Review all the Adjustments, section 3.0. If this is a new installation, set the VLP TIME CONSTANT digital switch at "0", and the VLP AC GAIN at "9" to sandbag the loop. Otherwise these values are known and should be set accordingly.

Connect the wires to the control and power plug. With power off check to see that there is a VREF signal. Confirm that its polarity and maximum value is correct.

Adjust the VREF signal to about 10% of its maximum, full speed value. IE...if the max value is +10V DC, set VREF at +1V DC.

Disconnect the wires to the disable inputs, terminals 7 and 8 of the control plug.

Turn on power and note green light. The motor should not turn. With a positive VREF signal present, briefly touch the wire to terminal 7 of the control plug. The motor should turn in the direction consistent with a (plus) + VREF and stabilize.

Remove the wire to terminal 7 and change VREF to a negative 10%. Briefly touch the wire to terminal 8 of the control plug. The motor should turn in the other direction and stabilize.

Remove power and restore the wires, permanently to terminals 7 and 8.

Set VREF to 0 which corresponds to zero motor speed. Turn on power and adjust the ZERO pot for zero motor speed.

Set VREF to its maximum value. Set the GAIN pot for desired maximum motor speed.

Adjust the VLP TIME CONSTANT and VLP AC GAIN digital rotary switches for desired response. See next section for help.

With a unit step or a slow square wave into the VREF input, monitor the motor speed by observing the end motion or a scope on the tach or armature of the motor. Adjust the VLP AC GAIN rotary switch for the number and/or height of overshoots. Adjust the VLP TIME CONSTANT for response time.

The current loop has similar adjustments located under the top cover of the AD5020. These are normally set at the factory and should not need to be adjusted. The ILP TIME CONSTANT is adjusted for maximum response time and the ILP AC GAIN is adjusted for one overshoot.

6.20 Setup for current loop.
Review all the Adjustments, section 3.0.

Connect the wires to the control and power plug. With power off check to see that there is a VREF signal. Confirm that its polarity and maximum value is correct.

Adjust the VREF signal to about 10% of its maximum, full speed value. IE...if the max value is +10V DC, set VREF at +1V DC.

Disconnect the wires to the disable inputs, terminals 7 and 8 of the control plug.

Turn on power and note green light. The motor should not turn. With a positive VREF signal present, briefly touch the wire to terminal 7 of the control plug. The motor should turn in the direction consistent with a (plus) + VREF.

Remove the wire to terminal 7 and change VREF to a negative 10%. Briefly touch the wire to terminal 8 of the control plug. The motor should turn in the other direction.

Remove power and restore the wires, permanently to terminals 7 and 8.

Set VREF to 0 which corresponds to zero motor current. Turn on power and adjust the ZERO pot for zero motor current.

Stall the motor and set VREF to its maximum value. Set the GAIN pot for desired maximum motor current. This value must be equal to or less than the current limit value.

The current loop has adjustments located under the top cover of the AD5020. These are normally set at the factory and should not need to be adjusted. The ILP TIME CONSTANT is adjusted for maximum response time and the ILP AC GAIN is adjusted for one overshoot.

SETUP FOR CONTROLLING CURRENT LIMIT THROUGH PIN 11 AT THE 12 PIN CONTROL PLUG

1. With power off, remove the 2 screws securing the top cover of the unit.
2. Look for SW13 and set the switches as shown below.

Turn switch # 1 on, (COM).

Turn switch # 2 off, (REL).

Turn switch # 3 on, (9V).

Turn switch # 4 off, (VIR).

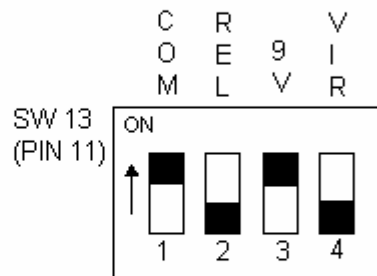

3. After switches have been set, put cover back on, making sure that the back edge of the cover hooks onto the back edge of the unit, then secure with the 2 screws.
4. Now you can connect a resistor from PIN 11 to COM, a 620 ohm 1/4 watt resistor for example, will give you about 1/2 of the total current limit that is set internally at the factory. If pin 11 is left open, (which is 9VDC open circuit) you will get maximum current limit set by the factory. Lowering this voltage reduces the current limit value. Zero volts is approximately 0 current limit (+/- 2 %). Zero volts, pin 11 to COM, must sink 13ma DC.

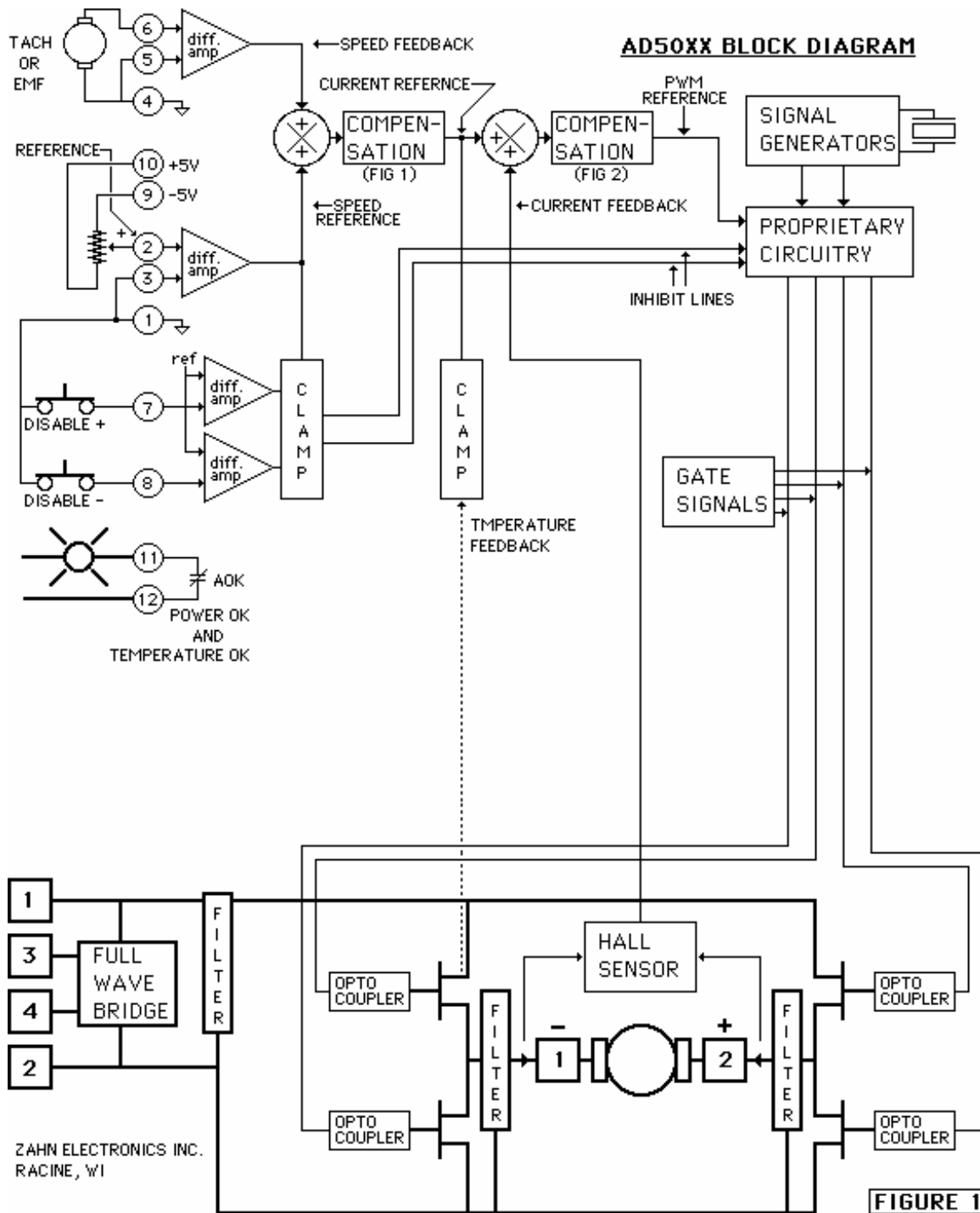

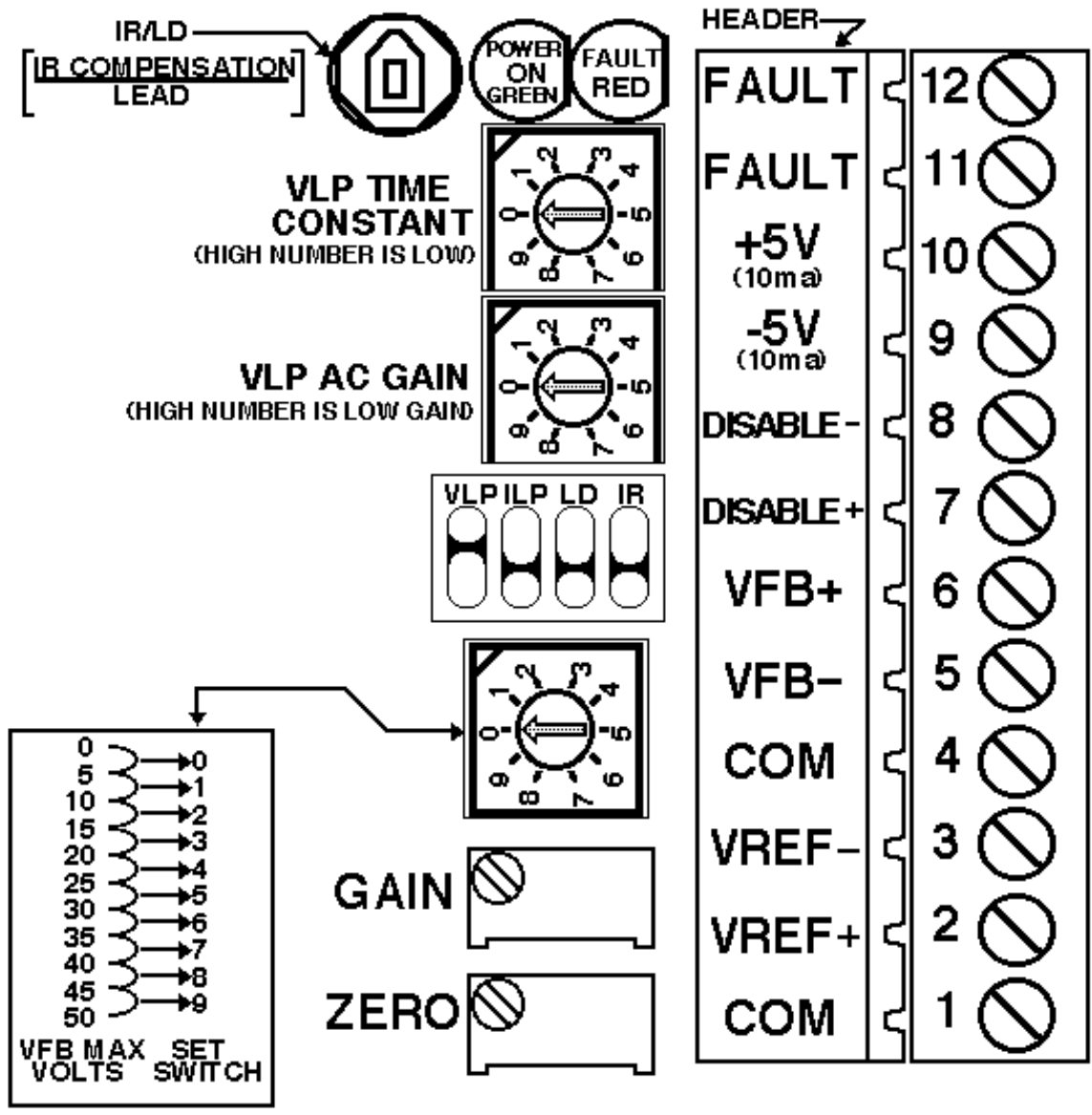

Figure 2.

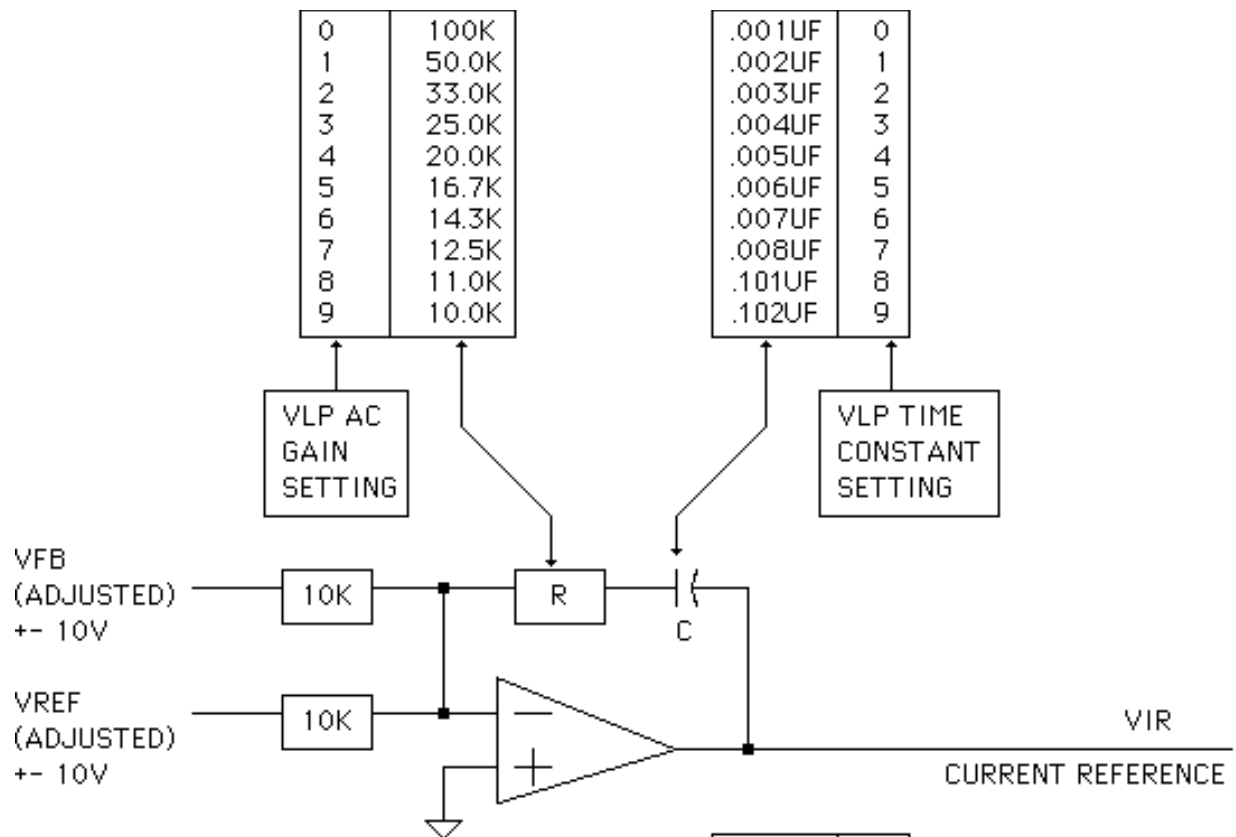
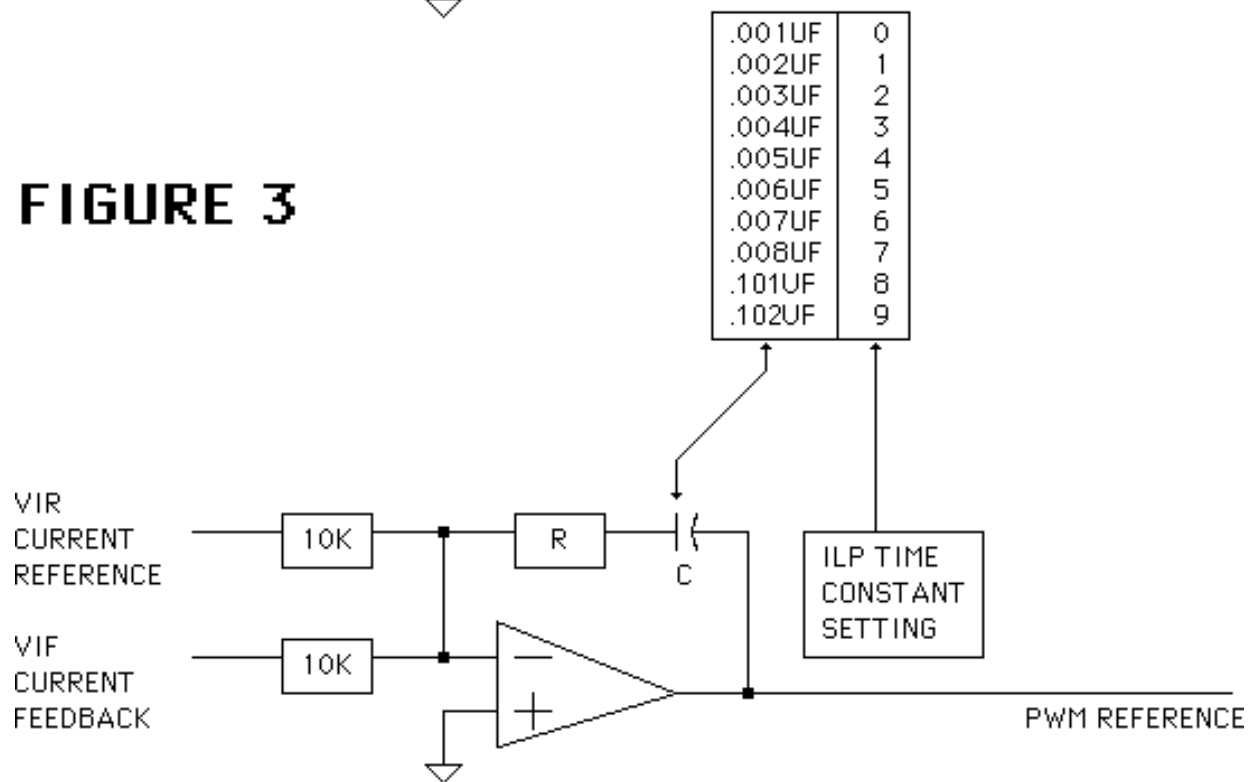
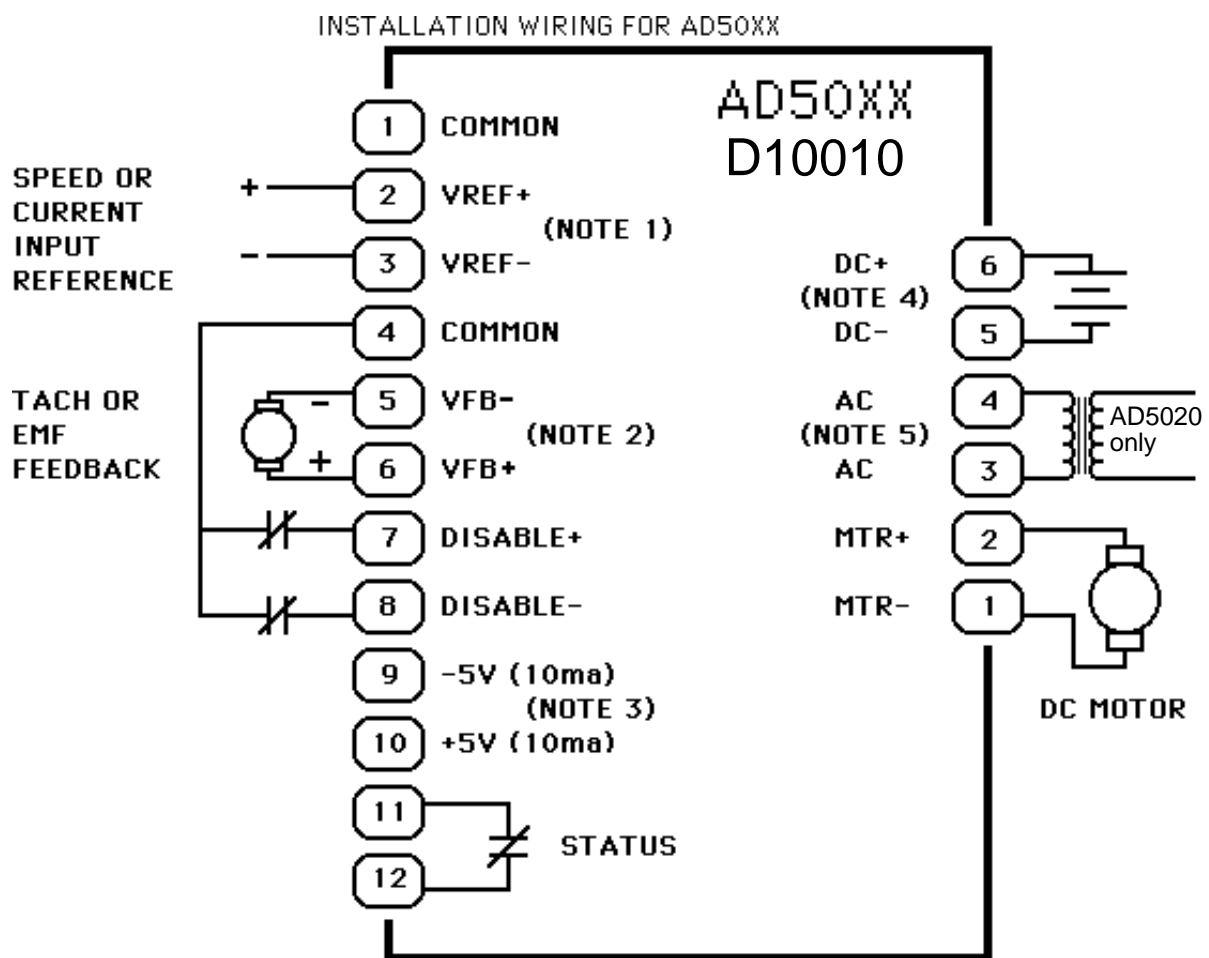

FIGURE 3





(NOTE 1) CONNECT ONE OF TERMINALS 1, 2 OR 3 TO COMMON OF THE SIGNAL SOURCE.

(NOTE 2) CONNECT EITHER TERMINAL 5 OR 6 TO COMMON (1 OR 4) WHEN USING TACH FEEDBACK. CONNECT TERMINAL 5 TO 1 AND 6 TO 2 WHEN USING EMF FEEDBACK. LEAVE TERMINALS 5 AND 6 VACANT FOR CURRENT MODE.

(NOTE 3) USE -5V AND OR +5V FOR EXCITATION OF A POTENTIOMETER FOR INPUT REFERENCE.

(NOTE 4) CONNECT DC SUPPLY TO TERMINALS 5 AND 6 ONLY IF TERMINALS 3 AND 4 ARE VACANT. DC SUPPLY RANGE IS 12 TO 50V.

(NOTE 5) CONNECT AC FROM TRANSFORMER TO TERMINALS 3 AND 4 ONLY IF TERMINALS 5 AND 6 ARE VACANT. AC SUPPLY RANGE IS 10 TO 35 VOLTS RMS.

(NOTE 6) A POSITIVE SIGNAL AT TERMINAL 2 (VREF+) WILL CAUSE A POSITIVE VOLTAGE AT TERMINAL 2 (MTR+).

FIGURE 4

AD50XX, INSTALLATION - MECHANICAL

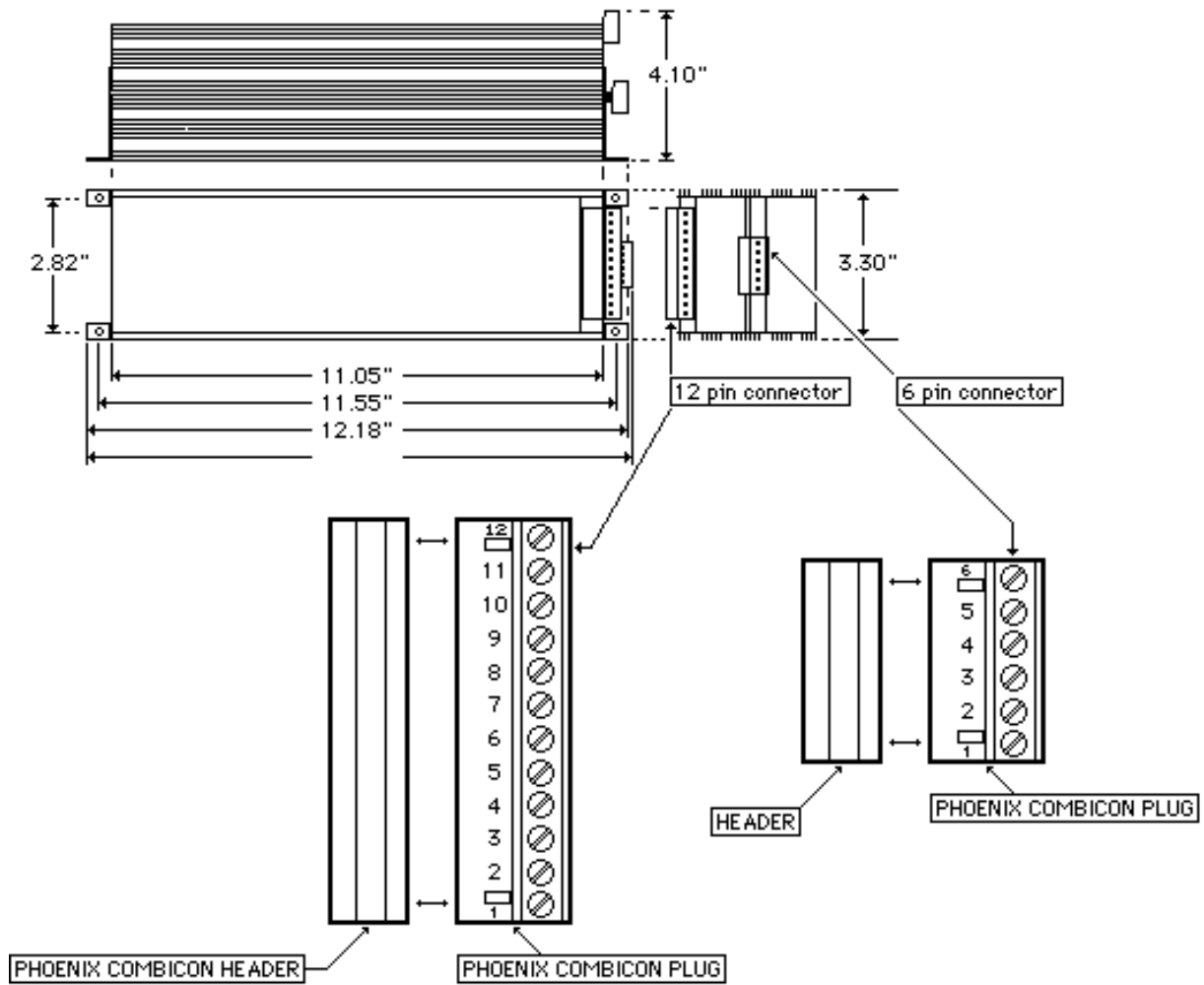

Zahn Electronics Inc. 4133 Courtney St. #5, Franksville, WI 53126
 262-835-9200 Fax=262-835-9201

FIGURE 5

AD50XX RESPONSE TIME

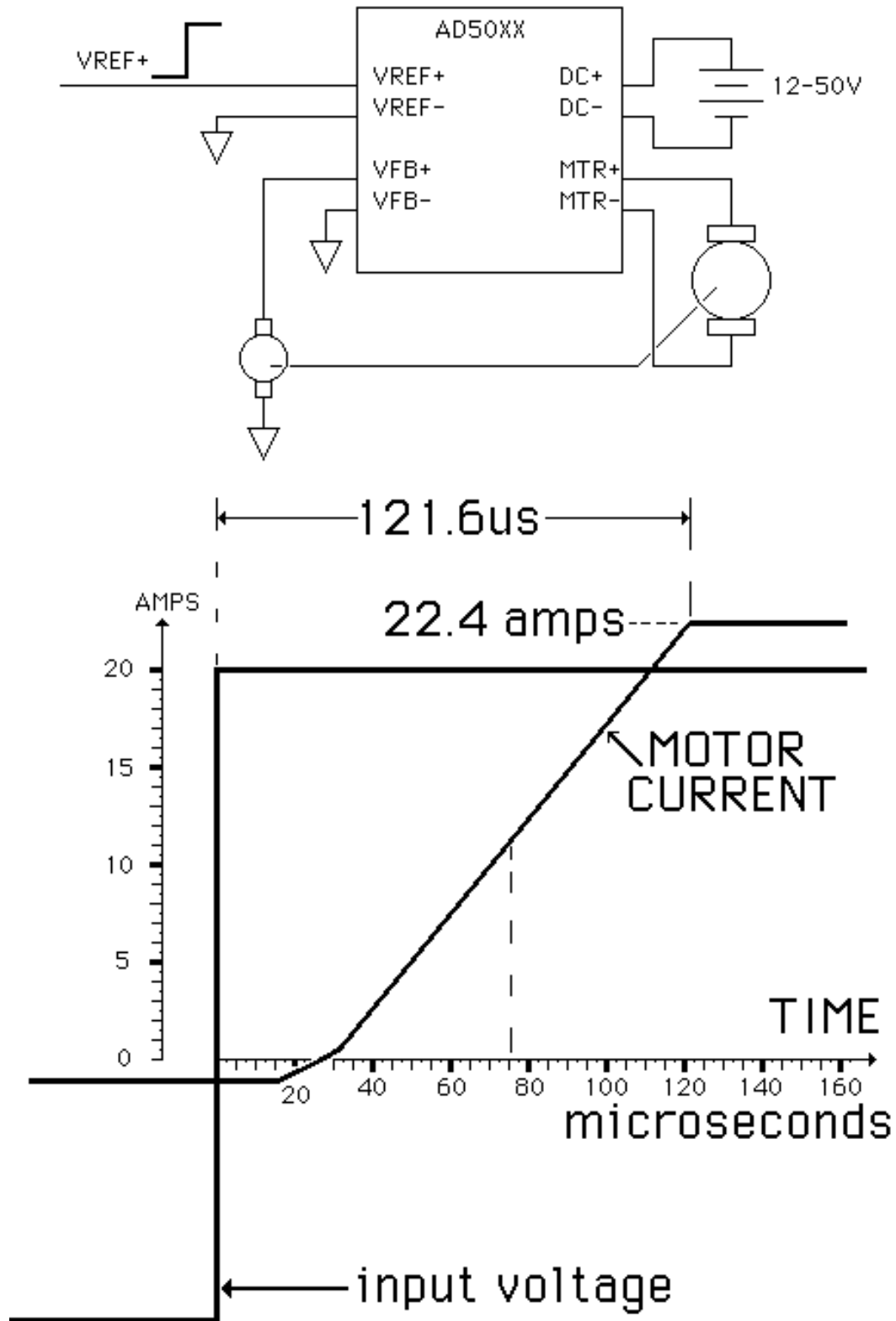

FIGURE 6