

TABLE OF CONTENTS, CHXXXXX-SU DC/DC CONVERTERS
(CH6090-SU, CH60125F-SU, CH63120F-SU, CH10065-SU, CH10090F-SU,
CH100105F-SU, CH20036-SU, CH20050F-SU, CH25032-SU, CH25045F-SU)

SECTION	TITLE	PAGE
1.00	Introduction and Description	2
2.00	Theory of Operation	3
3.00	Adjustments	4
3.11	IR COMP.....	4
3.12	VLP TIME CONSTANT.....	4
3.13	VLP AC GAIN.....	4
3.14	ILP TIME CONSTANT.....	4
3.15	VFB MAX VOLTS JUMPER.....	4
3.16	VLP or ILP selector.....	5
3.17	VFB VOLTAGE RANGE.....	5
3.18	ZERO.....	5
3.19	GAIN.....	5
3.20	Factory Adjustments.....	5
4.00	Wiring Instructions	5
4.10	CONTROL WIRING.....	5
4.11	INPUT COMMAND REFERENCE.....	5
4.12	VOLTAGE FEEDBACK.....	6
4.13	CURRENT FEEDBACK (Current Loop).....	6
4.14	DISABLE INPUTS.....	6
4.15	+5V AND -5V.....	6
4.16	STATUS, AOK.....	6
4.17	TERMINAL 11.....	6
4.18	POWER WIRING.....	7
5.00	Specifications	7
5.10	INSTALLATION MECHANICAL.....	7
5.20	ELECTRICAL SPECIFICATIONS (Control).....	7
5.30	ELECTRICAL SPECIFICATIONS (Power).....	8
5.40	OPERATIONAL MODES.....	9
5.50	STATUS.....	9
6.00	Setup Instructions	10
6.10	SETUP FOR EMF AND TACH FEEDBACK.....	10
6.20	SETUP FOR CURRENT LOOP.....	10
7.00	FIGURES 1-5	12

1.0 Introduction and Description

The CHXXXXX-SU is a high performance 2 quadrant, crystal controlled, Half H Bridge, configured in a buck topology. It is a compact, self contained unit with its own power supply, input power filter and regeneration circuit. Power to the unit is from a DC supply, or a battery. An external LC filter is usually required from the DC supply to the CH input. (LC225 from Zahn)

Faster response can be achieved because the switching frequency is exactly 31,250Hz.

Power Common from the DC power source is connected to Power Common of the load. The power circuit is not isolated. Hall sensors are used to sense the motor current and high speed opto couplers are used to control the power MOS FETs.

Compensation for the voltage loop, and feedback input is implemented by adjusting 10 position rotary switches. This assures stability of settings, predictable changes, and repeatability from unit to unit.

In Single quadrant mode the Disable input inhibits current from the source to the load. However the inherent diode from input to output forces the output voltage to be about 1 volt less than the input voltage.

In Two quadrant mode the Disable input is unique in that it immediately inhibits current to the load by clamping the reference internally to a near zero value but allows reverse current from the load. However the inherent diode from input to output forces the output voltage to be about 1 volt less than the input voltage. This is applicable when a battery is used as a load

The case temperature of the CHXXXXX-SU is monitored and in the event of an excessively high ambient temperature, current to the load is reduced automatically to hold the transistor temperatures to a safe level. A corresponding red LED turns on and contacts of a relay open to signal the host controller.

Separate +5V and -5V regulators are available to the user when a Potentiometer is used to vary the output voltage.

The converters can be configured in a current loop. Consult factory for this configuration.

2.0 Theory of Operation

Block Diagram.

Refer to Figure 1. The load is connected to terminals 6 and 5 of the control plug. The reference signal, -5 volts, is connected to terminal 2 of the control plug. These two signals are summed, and compensated and become the current reference of the system. The current feedback comes from the Hall Sensor which senses actual load current, and is summed with the afore mentioned current reference and is compensated. This signal essentially controls the on time of the pulse width modulator inside the "Proprietary Circuitry".

This circuit generates 2 gate drive signals, which are either on or off, that completely control the Half H Bridge in the lower part of the diagram. A crystal controlled oscillator is used to generate the saw tooth type waveforms that are needed in pulse width modulation. An inhibit line controls the half H bridge so that current to the load is restricted when an outside Disable signal is present.

A DC Supply or a battery is connected to power terminals 3+ and 2-. This Power input is heavily filtered so that EMI-RFI does not get back to the power source. The output of the Half H Bridge is filtered before going out to the load terminals 1 and 2.

Because the switching frequency is high and a large CLC filter is employed, filtering the output is practical and effective. The ripple voltage out, terminals 1 and 2, becomes negligible.

A thermistor is attached to the Aluminum case to which the power transistors are mounted which gives a thermal feedback. When the case temperature reaches 60 Degrees Centigrade, a fan is turned on to reduce the temperature for CHXXXXXF-SU units ["F" suffix]. For all other none "F" suffix units, the max allowed load current is slowly reduced. This protects the servo amplifier from overheating when the case temperature becomes excessive.

3.0 Adjustments

3.11 IR COMP. (Used instead of remote sensing.)

Figure 2 shows part of the label for a CH6090-SU. Other unit labels are similar. The IR compensation adjustment is shown. There is a selector header that allows IR COMP to be selected OUT or IN. If the selector is in the "IR" position, the POT labeled "IR/LD" will add some current signal to the voltage feedback that is present at terminals 5 and 6 of the control plug. The setting of this pot should be made when the load is varied. Attach an accurate voltmeter to the actual load, or at the point that you want to regulate. This will null out the voltage drop across the power wires from the CHXXXX-SU to the point of regulation. Remove the load, or reduce the load to the minimum current. Note the voltmeter reading. Reapply the full load and adjust the IR/LD pot so that the voltmeter reads the same as before.

3.12 VLP TIME CONSTANT.

This adjustment is a 10 position rotary switch that effectively allows 10 values of a capacitor that is configured in a lag network as shown in the left COMPENSATION box of Figure 1. Figure 3 shows the effect of this adjustment. Setting the arrow on this adjustment to the number 9 will introduce the maximum capacitance in the circuit and thus slow down the response time or time between overshoots. This adjustment has no effect when the VLP, ILP header is selected for ILP.

3.13 VLP AC GAIN.

This adjustment is a 10 position digital switch that effectively allows 10 values of a resistor that is configured in a lag network as shown in the left COMPENSATION box of Figure 1. Figure 3 shows the effect of this adjustment. Setting the arrow on this adjustment to the number 9 will introduce the minimum resistance in the circuit and thus reduce or eliminate overshoots. This adjustment affects the time constant of the loop and 3.12 above will have to be repeated. This adjustment has no effect when the VLP, ILP header is selected for ILP.

3.14 ILP TIME CONSTANT.

This adjustment is normally set at the factory. This 10 position rotary switch is found near the center of the top of the unit under the cover. This adjustment allows 10 values of a capacitor configured in a lag network as shown in the right COMPENSATION box of Figure 1. Figure 3 shows the effect of this adjustment. Setting the arrow on this adjustment to the number 9 will introduce the maximum capacitance into the circuit and thus slow down the response time or the time between overshoots.

3.15 VLP or ILP selector.

This adjustment is shown in Figure 2 and chooses whether the VREF input at terminals 2 and 3 of the control plug will control the voltage or current to the load. With the "VLP" DIP switch in the upper position, VREF will control the voltage to the load. With the "ILP" DIP switch in the upper position, VREF will control the current to the load. Do not Select both "VLP" and "ILP".

3.16 VFB MAX VOLTS.

This adjustment is shown in Figure 2 and scales the feedback voltage coming in at terminals 5 and 6 of the control plug. Use the chart in Figure 2 or on the label of the unit to select the correct maximum input voltage. This rotary switch will be set at the factory for the output voltage specified in the Customer Purchase order.

3.17 ZERO [Used when the output voltage or current are varied.]

This adjustment is shown in Figure 2 and is intended to set the load voltage to zero, when in the "VLP" mode; and to set the load current to zero, when in the "ILP" mode with the input reference voltage at terminals 2 and 3 of the control plug at 0 volts.

3.18 GAIN.

This adjustment is shown in Figure 2. With the input reference voltage at terminals 2 and 3 of the control plug set at the **maximum level**:

1. Set the load voltage when in the "VLP" mode;
2. Set the load current, when in the "ILP" mode.

When in the "ILP" mode, the current level cannot be set higher than the rated current limit level of the unit.

3.20 FACTORY ADJUSTMENTS.

On the side opposite from the customer plug connections there are 4 factory adjustments. These are current limit, current offset, and 2 "power" pots that need a special set up to optimize their settings. These adjustments should only be set by authorized personnel. The current limit setting is set at standard levels or set at special settings when specified on the customer's Purchase Order.

The Disable inputs are pulled up to +5V internal to the CHXXXXX-S, and these inputs have a threshold of 2.5 volts. These inputs can be pulled up to 12V with a threshold of 6V by changing a jumper inside the unit. Consult Factory for instructions.

4.00 Wiring Instructions.

4.10 Control Wiring.

The Control wiring consists of connecting low current carrying wires to the 12 terminal control plug located on the top right side of the unit. 22 gauge wire is adequate for all connections.

4.11 Input command reference.

Refer to Figure 4. The input command reference, VREF+ and VREF-, is the input signal that controls the load voltage or load current. If the reference is a single ended signal, VREF-, terminal 3 of the control plug, should be tied to common. VREF+ should be tied to the signal source and the signal source common should be tied to terminal 1 or 4 of the control plug, which is the converter common. VREF+, in this case will swing 0 to a negative DC value.

If a Pot is used for controlling the load voltage or current as a stand alone system, the -5V and +5V, terminals 9 and 10 of the control plug may be used. For single direction

control, connect -5V to one end of a 1000 --> 10000 ohm pot and the other end to common. Connect the wiper to either terminal 2 or 3 of the control plug, depending on what direction is desired (current mode only). A (minus) - voltage at terminal 2 of the control plug will cause a (plus) + voltage at power terminal 3. Connect the unused terminal (2 or 3) to common. Note that the polarities are confusing.

If bidirectional control is desired (current mode only), connect the Pot between the +5V and -5V. Do not draw more than 10ma out of either supply.

4.12 Voltage feedback.

Refer to Figure 4. Connect the LOAD+, power terminal 3, to the VFB- input of the control plug, terminal 5. Connect the LOAD-, power terminal 2, to the VFB+ input of the control plug, terminal 6. Connect common, control plug terminal 4 to control plug terminal 3. If long runs from the DCXXXXX-SU to the load are necessary, remote sensing can be used by running a separate pair of wires from the load terminals to the VFB+ and VFB- terminals instead. Connections should be made with a shielded twisted pair with the shield connected to common at the CHXXXXX-SU side. Note that the polarities are confusing.

4.13 Current feedback (Current loop).

Current feedback requires no connections to the VFB+ and VFB- inputs of the control plug, and should be left open. The current feedback is internal to the CHXXXXX-SU.

4.14 Disable inputs.

If the disable inputs are not to be used, connect terminals 7 and 8 to common.

If a single disable input is to inhibit the CHXXXXX-S, connect terminals 7 and 8 to each other and to a normally closed contact to common. An open collector transistor can be used with the collector connected to terminals 7 and 8 of the control plug.

4.15 +5V and -5V

There are two regulated supplies, separate from the internal supplies of the CHXXXXX that are intended to be used for Potentiometer excitation. These supplies are short circuit proof. See Section 4.11.

4.16 Status, AOK

Terminals 11 and 12 of the control plug are connected to a normally closed relay contact that opens up if there is a problem. This is the standard wiring of terminal 11. See 4.17, below. These terminals should be connected to the host supervisor for monitoring.

4.17 TERMINAL 11.

Terminal 11 can be programmed by selecting one of 4 DIP switch settings, SW13, located under the top cover.

COM Fault relay is tied to COM (common). Terminal 12 is the other side.

REL Terminal 11 is tied to the FAULT relay. Terminal 12 is the other side.

9V Terminal 11 is connected to the "9V" current limit node.

VIR Terminal 11 is connected to the "VIR" current reference node.

4.18 POWER WIRING.

All power connections are made to the 3, power lugs, located below the control plug.

Connect a DC supply to power terminals 3+ and 2-. Use the appropriate gauge wire, 10 ga for 30 amps, 12 ga for 20 amps, etc. If long runs are to be made, voltage drop should be calculated and compensated for in gauge and voltage level.

Connect the load to terminals 1 and 2. Use the appropriate gauge wire, 10 ga for 30 amps, 12 ga for 20 amps, etc. The polarity is such that power terminal 1 will go positive (+) when a negative voltage is applied to terminal 2 (VREF+) of the control plug. The load should cause a feedback such that terminal 5 (VFB-) of the control plug is driven positive. Note that the polarities are confusing.

5.00 Specifications.

5.10 Installation Mechanical.

The mechanical dimensions of the CHXXXX-SU are shown in Figure 5. The 12 pin control plug is on the top right side of the unit and the 3 power lugs are below it.

5.20 Electrical Specifications (Control).

Input resistances.

Terminal 1 and 4 are common (control plug).

Terminal 2, VREF+: 10k ohm to common.

20k ohm with respect to terminal 3.

Terminal 3, VREF-: 20k ohm to common.

Terminal 5, VFB-: CH60XXX-SU 50k ohm to common.

Terminal 5, VFB-: CH63XXX-SU 50k ohm to common.

Terminal 5, VFB-: CH100XXX-SU 100k ohm to common.

Terminal 5, VFB-: CH200XXX-SU 250k ohm to common.

Terminal 5, VFB-: CH250XXX-SU 250k ohm to common.

Terminal 5, VFB-: CH400XXX-SU 250k ohm to common.

Terminal 6, VFB+: CH60XXX-SU 60k ohm to common. 100k ohm with respect to terminal 6.

Terminal 6, VFB+: CH63XXX-SU 60k ohm to common. 100k ohm with respect to terminal 6.

Terminal 6, VFB+: CH100XXX-SU 110k ohm to common. 200k ohm with respect to terminal 6.

Terminal 6, VFB+: CH200XXX-SU 260k ohm to common. 500k ohm with respect to terminal 6.

Terminal 6, VFB+: CH250XXX-SU 260k ohm to common. 500k ohm with respect to terminal 6.

- Terminal 6, VFB+: CH400XXX-SU 260k ohm to common. 500k ohm with respect to terminal 6.
- Terminal 7, DISABLE+: 2.2k ohm pull up to +5V or +12V, depending on selector on board.
- Terminal 8, DISABLE-: 2.2k ohm pull up to +5V or +12V, depending on selector on board.

- Switching Frequency: 31,250Hz, crystal controlled
(15,625HZ, CH63XXXXX-SU, CH10090F/180-SU and CH10090F /200-SU)
- Gain Range, velocity mode: .86V to 10V for max output voltage.
- Gain Range, current mode: .86V to 10V for max current.
- Offset: Adjustable to zero with ZERO Pot.
- Drift: .1%/Deg C, max
- VFB Input voltage range: plus or minus max bus voltage.
- VREF input voltage range: -10 to +10 volts
- STATUS: NC Contact, 100 V DC, 10 Watt reed relay

5.30 Electrical Specifications (Power)

- Input Voltage, DC: CH60XXX-SU 12 to 42V
- CH63XXX-SU 12 to 61V
- CH100XXX-SU 24 to 78V
- CH200XXX-SU 80 to 158V
- CH250XXX-SU 80 to 198V
- CH400XXX-SU 80 to 298V

Output Voltage, DC: (Must be 2 Volts higher than the Input Voltage)

- CH60XXX-SU 14 to 44V
- CH63XXX-SU 14 to 63V
- CH100XXX-SU 26 to 80V
- CH200XXX-SU 82 to 160V
- CH250XXX-SU 82 to 200V
- CH400XXX-SU 82 to 300V

Example: A CH10065-SU has an input voltage of 38 to 56 volts. The output voltage is set at 72 volts. 72 Volts is within the range of 26 to 80V and the output voltage is 16 volts higher than the maximum input voltage of 56 volts.

Continuous Input Current: (maximum allowed)

- CH6090-SU 90A
- CH60125F-SU 125A
- CH10065-SU65A
- CH10090F-SU 90A
- CH20042-SU42A
- CH20060F-SU 60A
- CH25032-SU32A
- CH25045F-SU 45A
- CH40020F*-SU 20A

Continuous Output Current: (maximum allowed)

The continuous Output current must be calculated. It depends on, Vin, Iin, Vout, and the efficiency of the unit.

$$I_{out(max)} = (V_{in} \cdot I_{in} \cdot \text{Efficiency}) / V_{out} = P_{out} / V_{out}$$

Example: For a CH10065-SU with Vin=38v, Iin=65A, Vout=72v, Efficiency=.90, Iout(max)=(38*65*.90)/72=30.8A, where Pout is 2223 Watts.

5.40 Operational Modes.

1. Voltage Loop, without IR Compensation, Single quadrant.
2. Voltage Loop, with IR Compensation, Single quadrant.
3. Voltage Loop, without IR Compensation, Two quadrant.
4. Voltage Loop, with IR Compensation, Two quadrant.
5. Current Loop, Single quadrant.
6. Current Loop, Two quadrant.

5.50 Status

The Status of the CHXXXXX-SU is conveyed by a normally closed contact available at terminals 11 and 12 of the control plug. The Status is also referred to as fault and "AOK". The red LED turns on and the contacts are opened if:

1. There is no power to the unit.
2. The internal power supplies have failed.
3. The CHXXXXX-S is in thermal limiting.

6.00 Setup Instructions.

6.10 Setup for Voltage Loop.

Review all the Adjustments, section 3.0. If this is a new installation, set the VLP TIME CONSTANT digital switch at "9", and the VLP AC GAIN at "0" to sandbag the loop. Otherwise these values are known and should be set accordingly.

Connect the wires to the control and power plug. With the load disconnected, turn power on and measure the output voltage. It should be set to desired value. The green light should be on.

Remove the wires to terminals 7 and 8. The output should go to zero. Remove power and restore the wires, permanently to terminals 7 and 8.

[For variable output only.] Set VREF to 0 which corresponds to zero output. Turn on power and adjust the ZERO pot for zero volts out.

Set VREF to its maximum value. Set the GAIN pot for desired output voltage.

Adjust the VLP TIME CONSTANT and VLP AC GAIN digital rotary switches for desired response. See next section for help.

With a unit step load change, either full or partial load, monitor the output voltage. Adjust the VLP AC GAIN rotary switch for the number and/or height of overshoots. Adjust the VLP TIME CONSTANT for response time.

The current loop has a similar adjustment located under the top cover of the CHXXXX-SU. This is normally set at the factory and should not need to be adjusted.

6.20 Setup for current loop.

Review all the Adjustments, section 3.0.

Connect the wires to the control and power screws. With power off check to see that there is a VREF signal. Confirm that its polarity and maximum value is correct.

Adjust the VREF signal to about 10% of its maximum, full speed value. IE... if the max value is +10V DC, set VREF at +1V DC.

Disconnect the wires to the disable inputs, terminals 7 and 8 of the control plug.

Turn on power and note green light. The output current should be zero. With a positive VREF signal present, briefly touch the wire to terminal 7 of the control plug. Current should flow in the direction consistent with a (plus) + VREF.

Remove power and restore the wires, permanently to terminals 7 and 8.

Set VREF to 0 which corresponds to zero load current. Turn on power and adjust the ZERO pot for zero motor current.

Set VREF to its maximum value. Set the GAIN pot for desired maximum motor current. This value must be equal to or less than the current limit value of the unit.

The current loop has an adjustment located under the top cover of the CHXXXXX-SU. This is normally set at the factory and should not need to be adjusted.

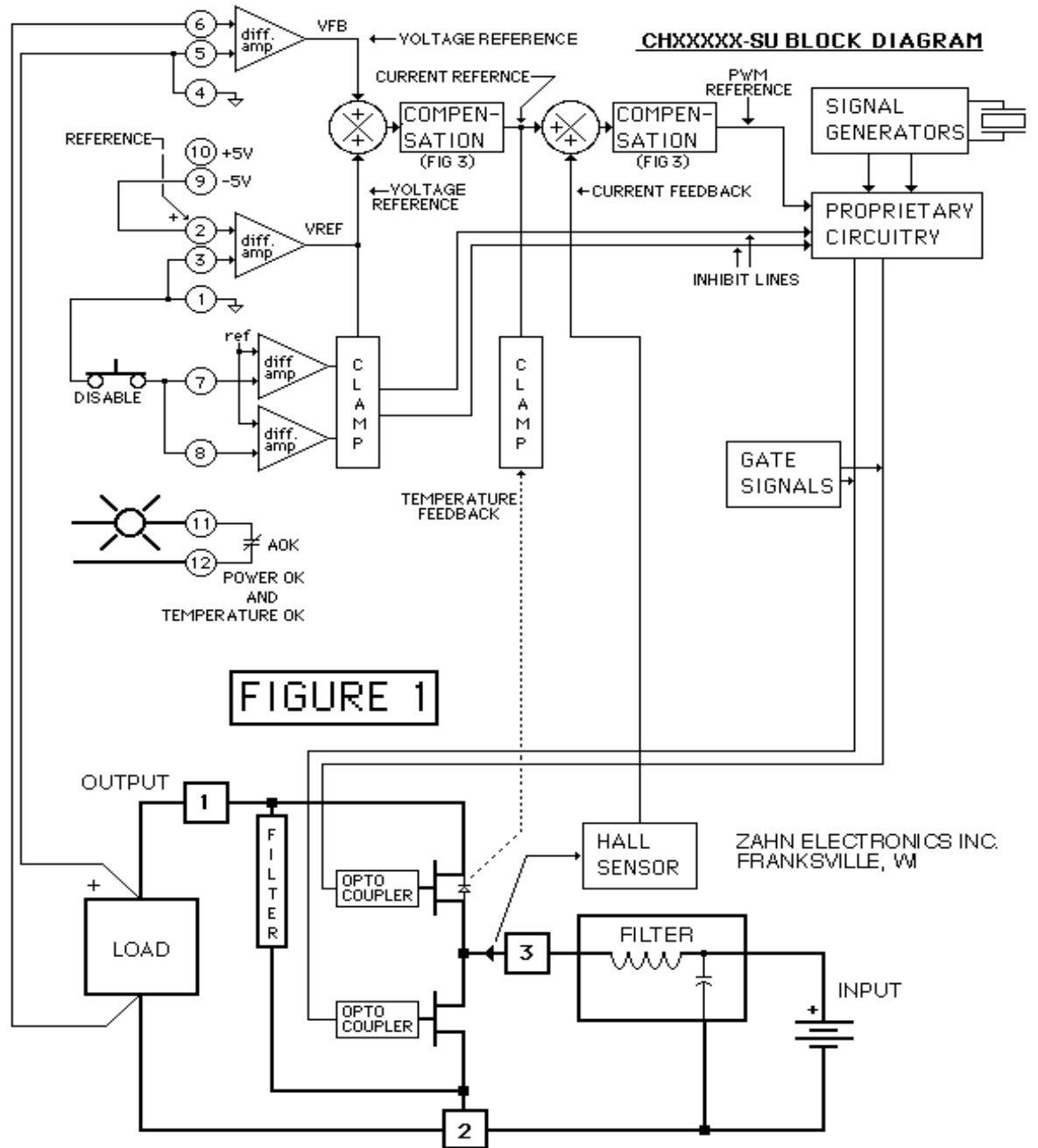

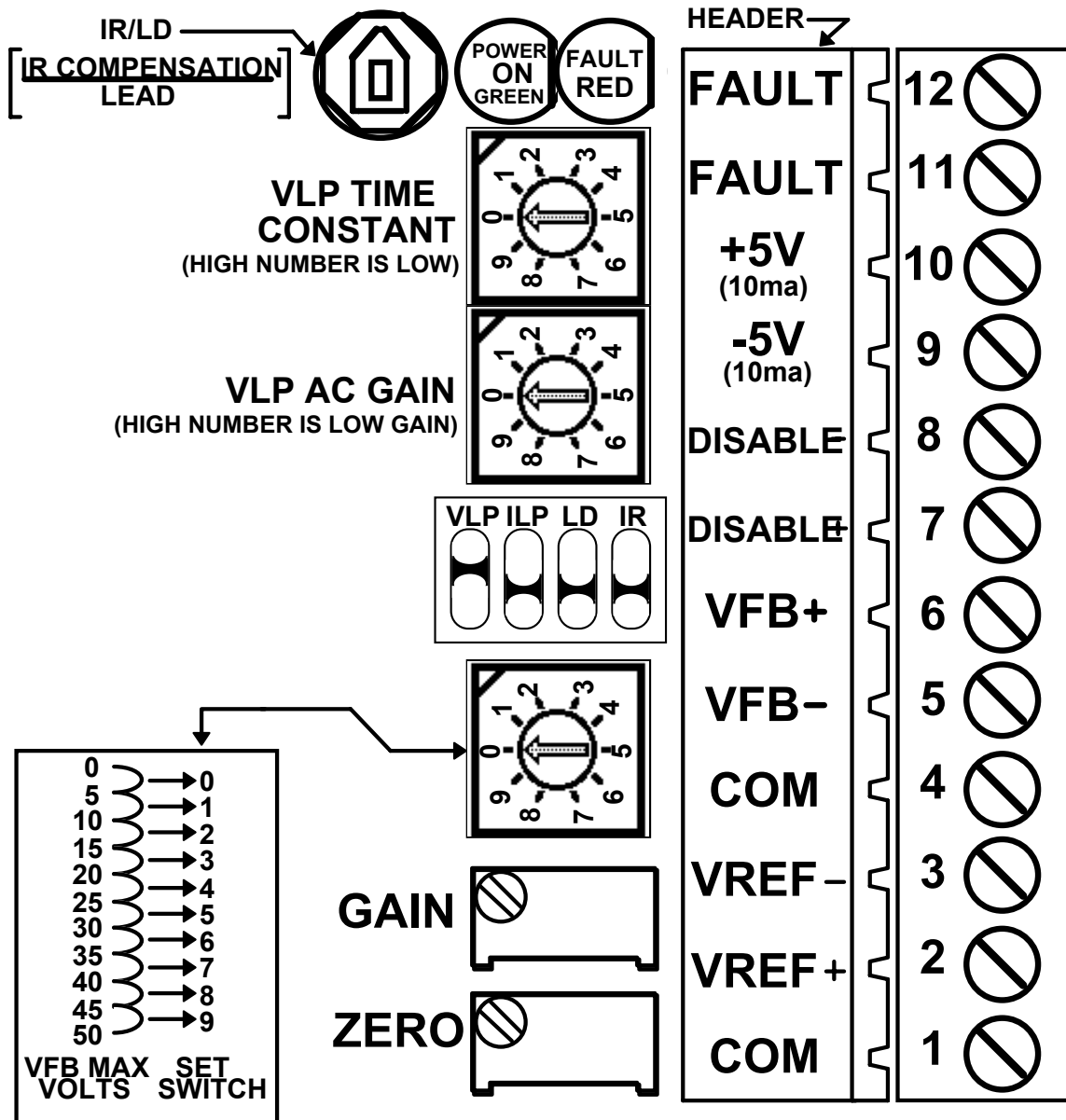

FIGURE 2

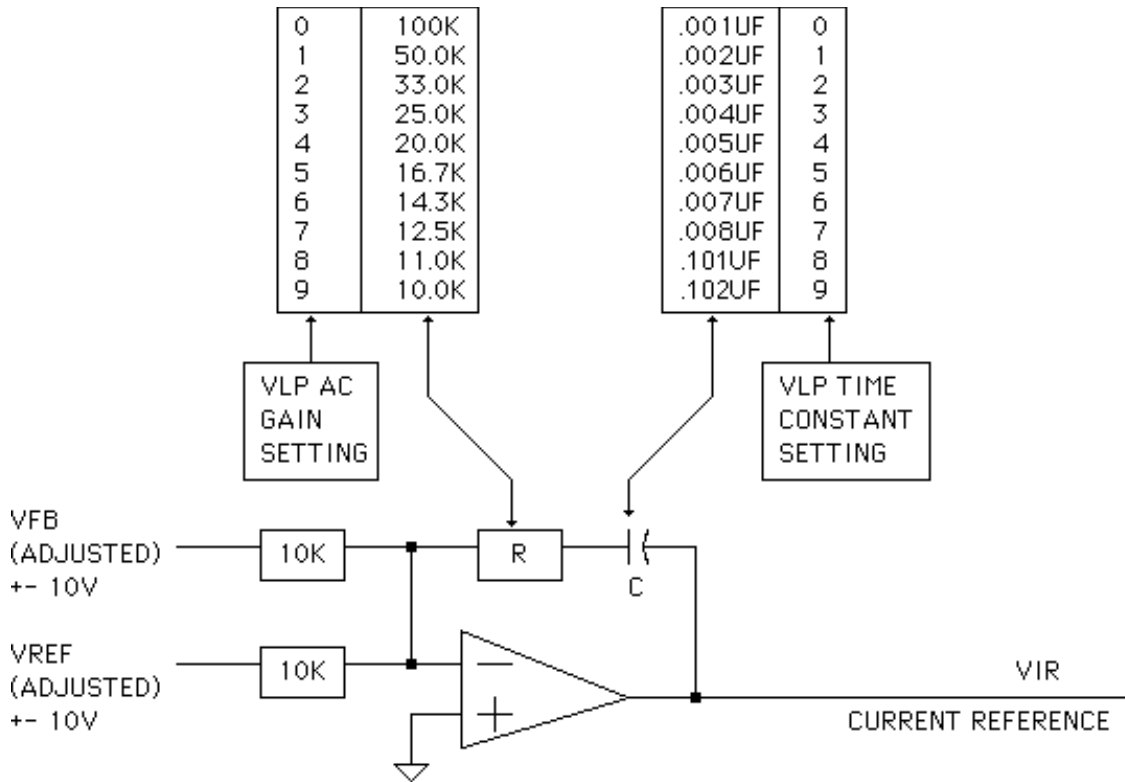
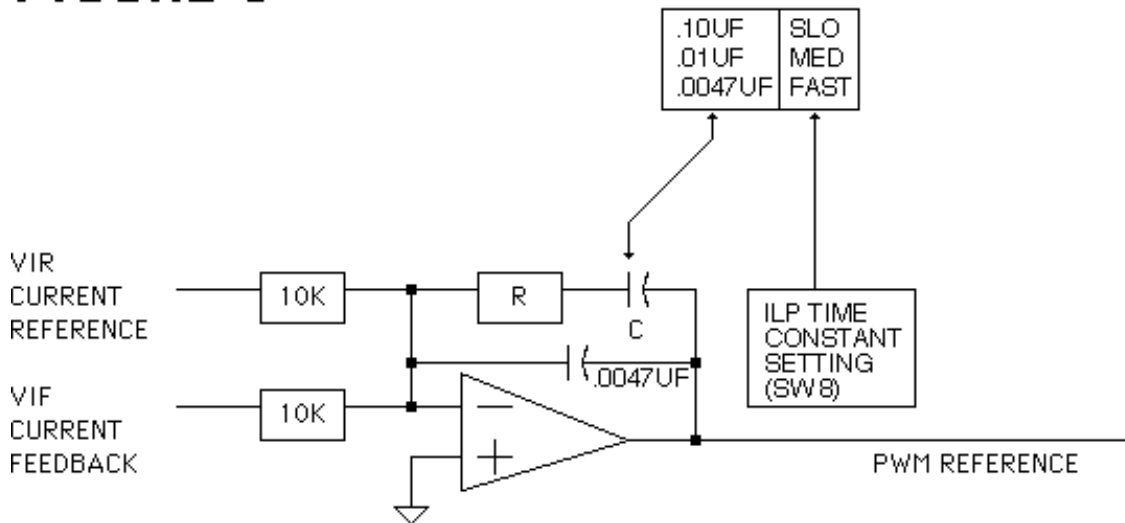

FIGURE 3



INSTALLATION WIRING, CHXXXX-SU

10-02

DC/DC CONVERTER WIRING

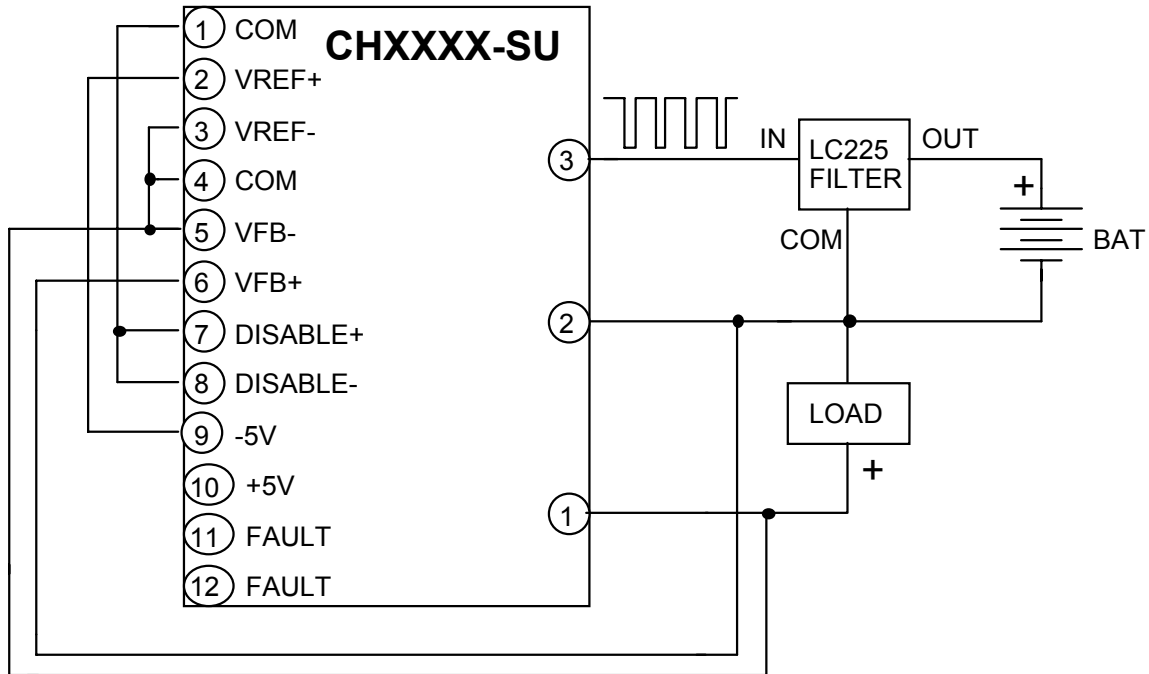

NOTES:

- 1 WIRE FEEDBACK CONNECTIONS FROM LOAD TO TERMINALS 5 AND 6 DIRECTLY TO LOAD FOR REMOTE SENSING.
- 2 ADJUST GAIN POT FOR DESIRED OUTPUT VOLTAGE.
- 3 CONNECT FAULT CIRCUIT TO TERMINALS 11 AND 12 IF DESIRED. CONTACTS OPEN IF FAULT.

FIGURE 4.

**ZAHN ELECTRONICS INC.
FRANKSVILLE, WI**

**INSTALLATION DRAWING FOR
CHXXXXX-SU, CHXXXXF-SU**

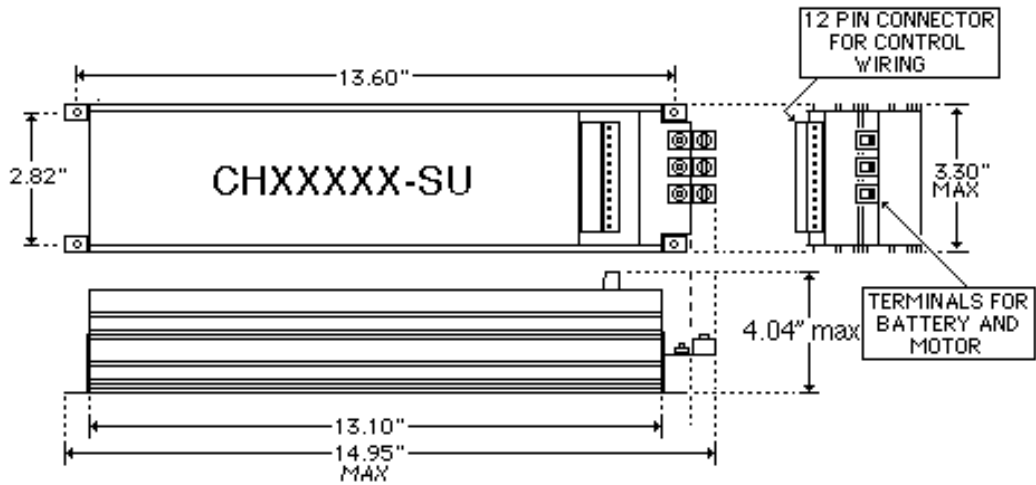

ALL TOLERANCES ARE ± 0.020 " EXCEPT MAX DIMENSIONS.

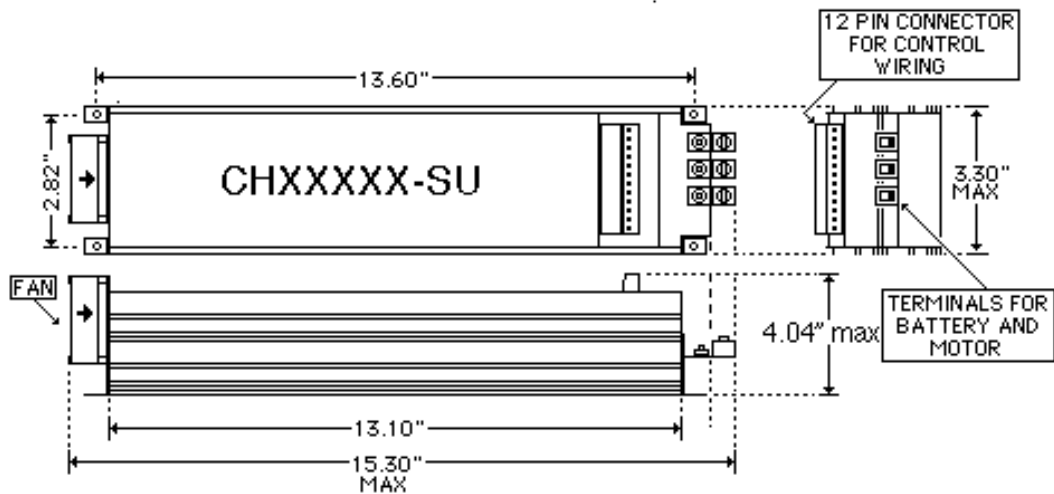

FIGURE 5