

TABLE OF CONTENTS, CHXXXXX-SS, DC/DC CONVERTERS
(CH60250F-SS, CH63250F-SS, CH100180F-SS, CH100210F-SS, CH150160F-SS, CH200120F-SS, CH25090F-SS, CH40040F-SS)

SECTION	TITLE	PAGE
1.00	Introduction and Description	2
	Figure 1. Block diagram	4
2.00	Theory of Operation	5
	Figure 2. label	6
3.00	Adjustments	7
3.11	IR COMP.....	7
3.12	VLP TIME CONSTANT.....	7
3.13	VLP AC GAIN.....	7
3.14	ILP TIME CONSTANT.....	7
	Figure 3. Compensation circuit.	8
3.15	VLP or ILP selector.....	9
3.16	VFB VOLTAGE RANGE.....	9
3.17	ZERO.....	9
3.18	GAIN.....	9
3.19	Factory Adjustments.....	9
4.00	Wiring Instructions	10
	Figure 4. Wiring diagram.	10
4.10	CONTROL WIRING.....	10
4.11	INPUT COMMAND REFERENCE.....	10
4.12	VOLTAGE FEEDBACK.....	11
4.13	CURRENT FEEDBACK (Current Loop).....	11
4.14	DISABLE INPUTS.....	11
4.15	+5V AND -5V.....	11
4.16	STATUS, AOK.....	11
4.17	POWER WIRING.....	12
5.00	Specifications	13
5.10	INSTALLATION MECHANICAL.....	13
	Figure 5. Installation drawing.	13
5.20	ELECTRICAL SPECIFICATIONS (Control).....	14
5.30	ELECTRICAL SPECIFICATIONS (Power).....	14
5.40	OPERATIONAL MODES.....	14
5.50	STATUS.....	14
6.00	Setup Instructions	15
6.10	SETUP FOR VOLTAGE LOOP.....	15
6.20	Setup for Controlling Current Limit. (Pin 11)	16

1.0 Introduction and Description

The **CH unit**, referred to as the **CH unit**, from now on, is a high performance 2 quadrant, crystal controlled, Dual Half H Bridge, configured in a buck topology. It can be configured in 1 quadrant operation. It is a compact, self contained unit with its own power supply, input power filter and regeneration circuit. Power to the unit is from a DC supply, fuel cell, or a battery. An external LC filter is usually required from CH output to load, on the SS units. (LC225 from Zahn)

There are two half bridges in parallel, in each unit. Each half bridge has 10 transistors in parallel on the top, and 10 transistors in parallel on the bottom. This topology requires separate LC filters, one LC for each half bridge. There are a total of 40 transistors.

Faster response can be achieved because the switching frequency is exactly 31,250Hz.

Power Common from the DC power source is connected to Power Common of the load. The power circuit is not isolated. Hall sensors are used to sense the motor current and high speed opto couplers are used to control the power MOS FETs.

Power Common is isolated from the Control Common in ILP (Current loop configuration). Power Common is not isolated from Control Common in VLP (Voltage loop configuration). There are high value resistors that feedback the output voltage. It could be considered still isolated, since the resistors are the only connections from the control to the power circuit.

Compensation for the voltage loop, and feedback input is implemented by adjusting 10 position rotary switches. This assures stability of settings, predictable changes, and repeatability from unit to unit.

The Disable inputs should be tied together.

There are two modes of operation:

- 1 step down, single quadrant. (current one direction)
- 2 step down, two quadrant. (current both directions)

Disabling will cause the output to go to 0.

Im218. Step Down DC/DC Converter. 1/06 Zahn Electronics, Inc. FRANKSVILLE, WI

The case temperature of the **CH unit** is monitored and in the event of an excessively high ambient temperature, current to the load is reduced automatically to hold the transistor temperatures to a safe level. A corresponding red LED turns on and contacts of a relay open to signal the host controller.

Separate +5V and -5V regulators are available to the user when a Potentiometer is used to vary the output voltage.

The converter can be configured in a current loop. Another way to effectively have a current loop, is to configure the CH unit in a voltage loop, and control the current limit. In this configuration, pin 11 of the control plug controls the current limit value. Consult factory for this configuration.

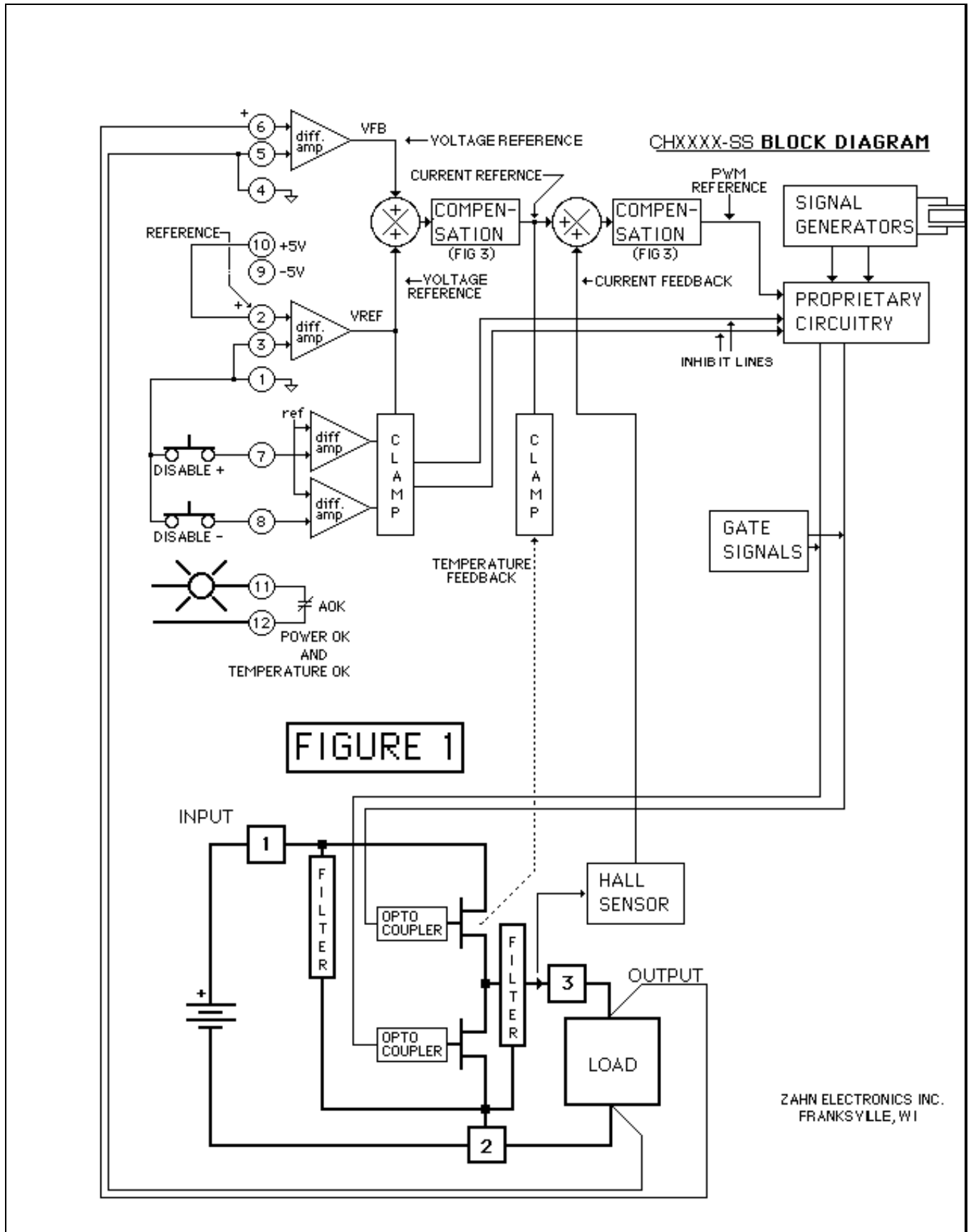

2.0 Theory of Operation

Block Diagram.

Refer to Figure 1. The load is connected to terminals 6 and 5 of the control plug. The reference signal, +5 volts, is connected to terminal 2 of the control plug. These two signals are summed, and compensated and become the current reference of the system. The current feedback comes from the Hall Sensor which senses actual load current, and is summed with the afore mentioned current reference and is compensated. This signal essentially controls the on time of the pulse width modulator inside the "Proprietary Circuitry".

This circuit generates 2 gate drive signals, which are either on or off, that completely control the Half H Bridge in the lower part of the diagram. A crystal controlled oscillator is used to generate the saw tooth type waveforms that are needed in pulse width modulation. An inhibit line controls the half H bridge so that current to the load is restricted when an outside Disable signal is present.

A DC Supply or a battery is connected to power terminals 1+ and 2-. This Power input is heavily filtered so that EMI-RFI does not get back to the power source. The output of the Half H Bridge is filtered before going out to the load terminals 3 and 2. This is normally an LC filter from Zahn.

Because the switching frequency is high and the peak to peak output of the half bridge is the amplitude of the bus, and not double the bus, filtering the output of the bridge is practical and effective. The ripple voltage out, across the load becomes negligible.

A thermistor is attached to the Aluminum case to which the power transistors are mounted which gives a thermal feedback. When the case temperature reaches 60 Degrees Centigrade, a fan is turned on to reduce the temperature of the **CH unit**. If the fan fails to turn on, or the ambient temperature is too high, the max allowed load current is slowly reduced. This protects the servo amplifier from overheating when the case temperature becomes excessive.

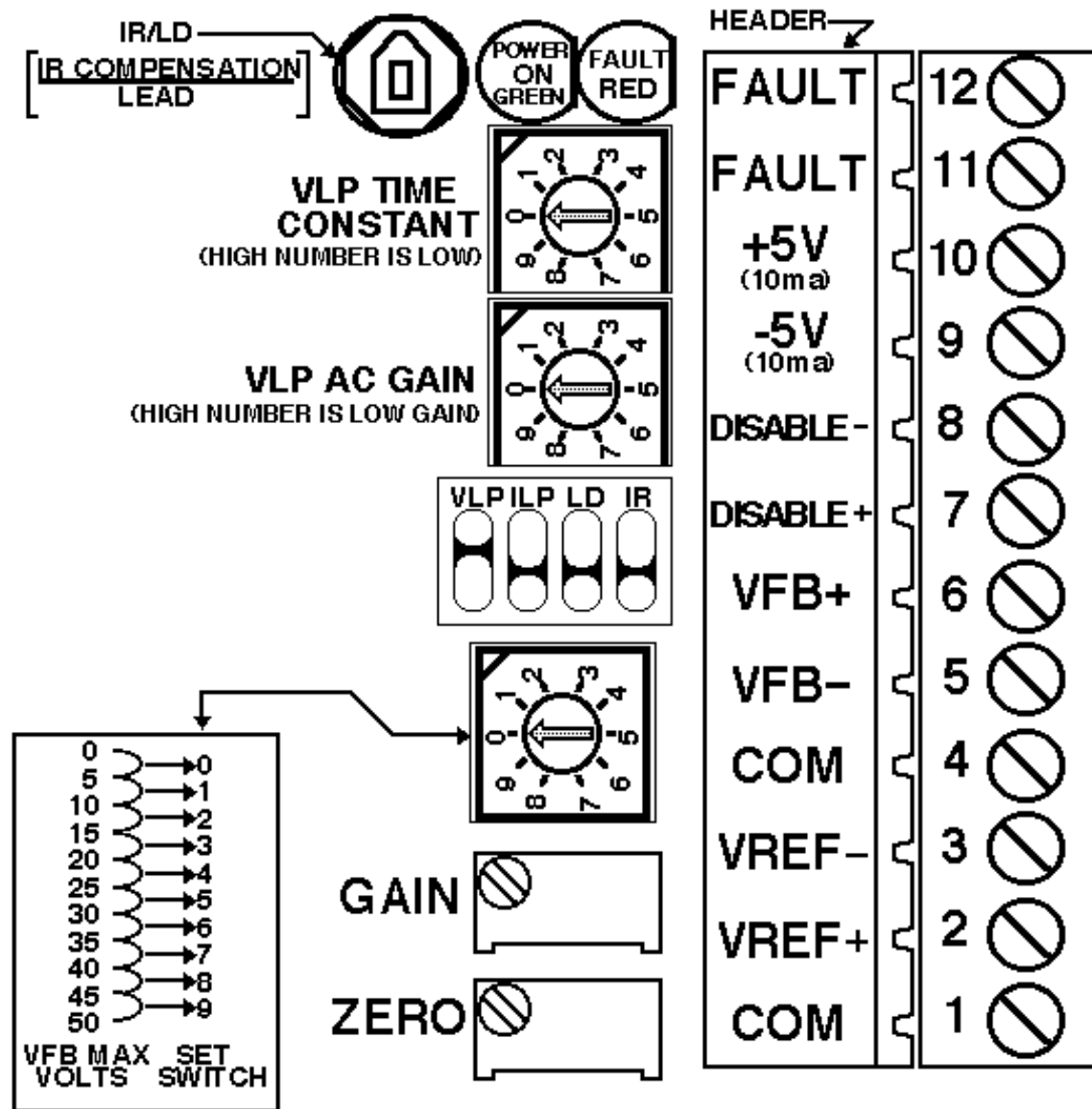

Figure 2

3.0 Adjustments

3.11 IR COMP. (Can be used instead of remote sensing.)

Figure 2 shows the label for a typical **CH unit**. Other unit labels are similar. The IR compensation pot adjustment is shown. There is a dip switch that allows IR COMP to be selected OUT or IN. If the dip switch is in the "IR" position, the POT labeled "IR/LD" will add some current signal to the voltage feedback that is present at terminals 5 and 6 of the control plug. The setting of this pot should be made when the load is varied. Attach an accurate voltmeter to the actual load, or at the point that you want to regulate. This will null out the voltage drop across the power wires from the **CH unit** to the point of regulation. Remove the load, or reduce the load to the minimum current. Note the voltmeter reading. Reapply the full load and adjust the IR/LD pot so that the voltmeter reads the same as before.

3.12 VLP TIME CONSTANT.

This adjustment is a 10 position rotary switch that effectively allows 10 values of a capacitor that is configured in a lag network as shown in the left COMPENSATION box of Figure 1. Figure 3 shows the effect of this adjustment. Setting the arrow on this adjustment to the number 9 will introduce the maximum capacitance in the circuit and thus slow down the response time or time between overshoots. This adjustment has no effect when the VLP, ILP switch is selected for ILP.

3.13 VLP AC GAIN.

This adjustment is a 10 position digital switch that effectively allows 10 values of a resistor that is configured in a lag network as shown in the left COMPENSATION box of Figure 1. Figure 3 shows the effect of this adjustment. Setting the arrow on this adjustment to the number 9 will introduce the minimum resistance in the circuit and thus reduce or eliminate overshoots. This adjustment affects the time constant of the loop and 3.12 above will have to be repeated. This adjustment has no effect when in ILP.

3.14 ILP TIME CONSTANT.

This adjustment is normally set at the factory. This 4 position dip switch is found near the center of the top of the unit under the cover. This adjustment allows 3 values of a capacitor configured in a lag network as shown in the right COMPENSATION box of Figure 1. Figure 3 shows the effect of this adjustment. Setting "SLO" will introduce the maximum capacitance into the circuit and thus slow down the response time or the time between overshoots.

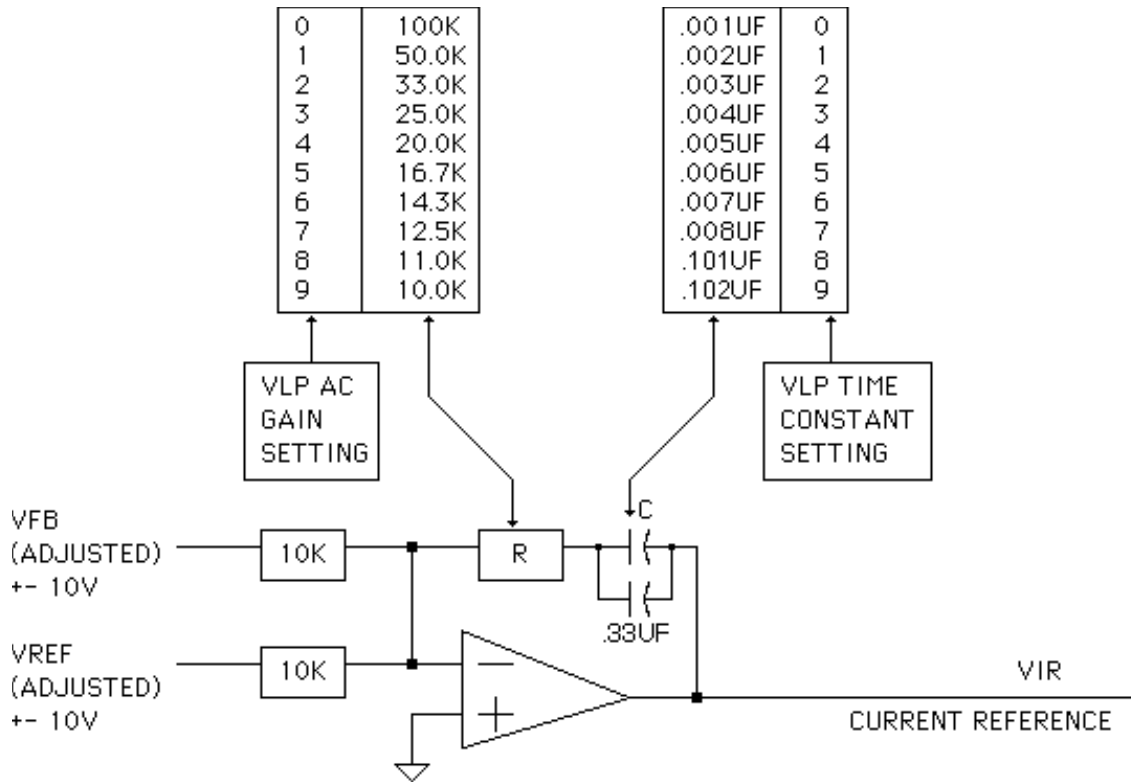
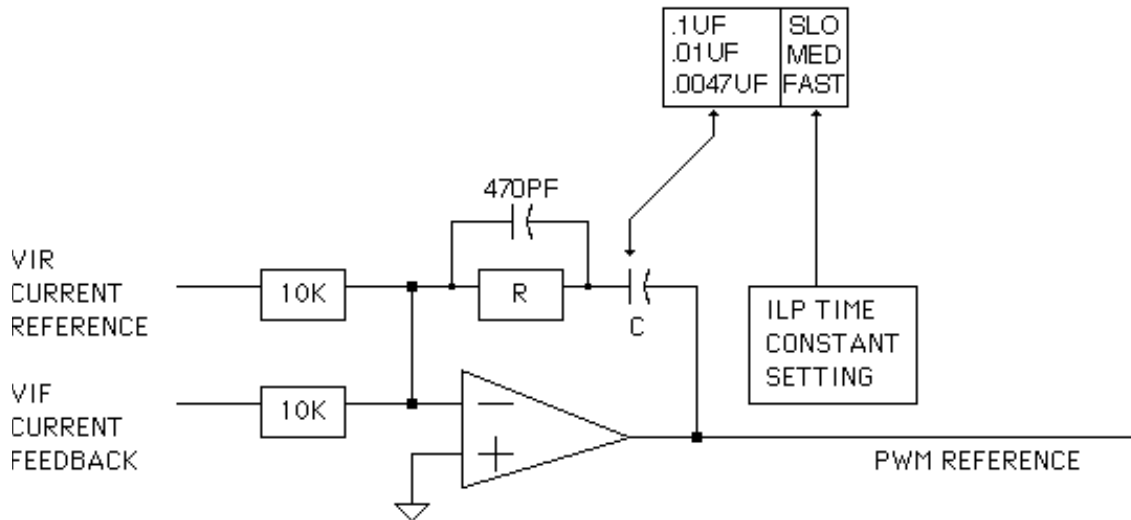

FIGURE 3



3.15 VLP or ILP selector.

This adjustment is shown in Figure 2 and chooses whether the VREF input at terminals 2 and 3 of the control plug will control the load voltage or current. With the VLP DIP SWITCH in the upper position, load voltage will be controlled. With the ILP DIP SWITCH in the upper position, load current will be controlled.

3.16 VFB VOLTAGE RANGE.

This adjustment is shown in Figure 2 and scales the feedback voltage coming in at terminals 5 and 6 of the control plug. Use the chart in Figure 2 or on the label of the unit to select the correct maximum input voltage. This switch setting will be set at the factory for the output voltage specified in the Customer Purchase order.

3.17 ZERO [Used when the output voltage or current are varied.]

This adjustment is shown in Figure 2 and is intended to set the load voltage to zero, when in the "VLP" mode; and to set the load current to zero, when in the "ILP" mode with the input reference voltage at terminals 2 and 3 of the control plug at 0 volts.

3.18 GAIN.

This adjustment is shown in Figure 2. With the input reference voltage at terminals 2 and 3 of the control plug set at the **maximum level**:

1. Set the load voltage when in the "VLP" mode;
2. Set the load current, when in the "ILP" mode.

When in the "ILP" mode, the current level cannot be set higher than the rated current limit level of the unit.

3.19 FACTORY ADJUSTMENTS.

On the side opposite from the customer plug connections there are 6 factory adjustments. These are current limit, current offset, and 4 "power" pots that need a special set up to optimize their settings. These adjustments should only be set by authorized personnel. The current limit setting is set at standard levels or set at special settings when specified on the customer's Purchase Order.

The Disable inputs are pulled up to +5V internal to the **CH unit**. and these inputs have a threshold of 2.5 volts. These inputs can be pulled up to 12V with a threshold of 6V by changing a DIP SWITCH inside the unit. Consult Factory for instructions.

4.00 Wiring Instructions.

4.10 Control Wiring.

The Control wiring consists of connecting low current carrying wires to the 12 terminal control plug located on the top left side of the unit. 22 gauge wires are adequate for all connections.

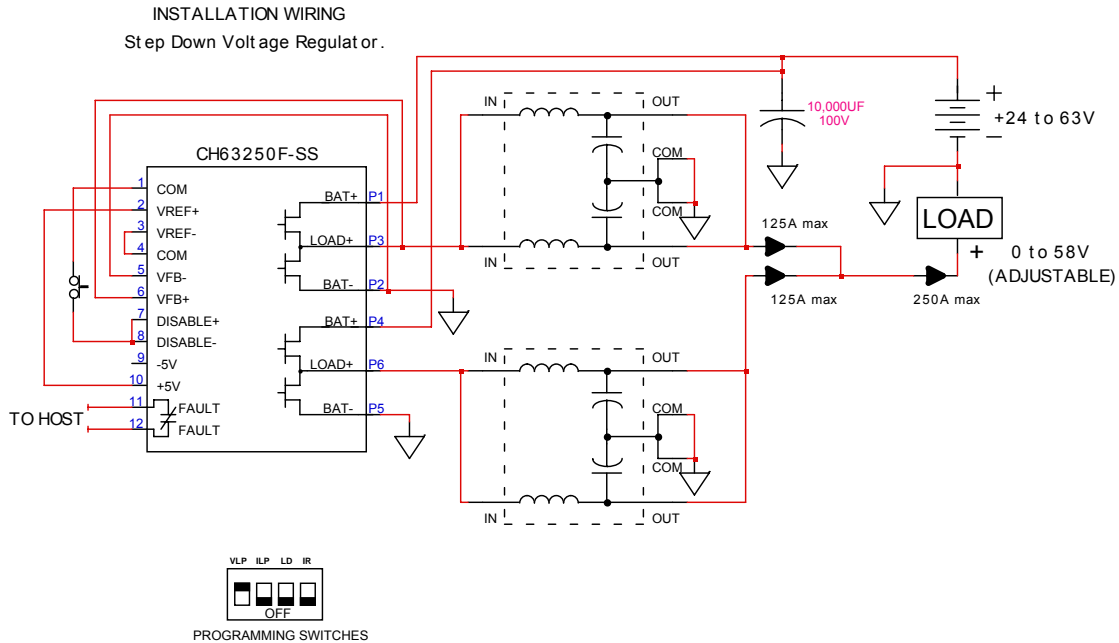

- NOTES:
- 1 ADJUST GAIN POT FOR DESIRED LOAD VOLTAGE.
 - 2 WIRE DISABLE INPUT TO NC CONTACT.

Figure 4.

4.11 Input command reference.

Refer to Figure 4. The input command reference, VREF+ and VREF-, is the input signal that controls the load voltage or load current. If the reference is a single ended signal, VREF-, terminal 3 of the control plug, should be tied to common. VREF+ should be tied to the signal source and the signal source common should be tied to terminal 1 or 4 of the control plug, which is the converter common.

If a Pot is used for controlling the load voltage or current as a stand alone system, the -5V and +5V, terminals 9 and 10 of the control plug may be used. For single direction control, connect +5V to one end of a 1000 --> 10000 ohm pot and the other end to common. Connect the wiper to either terminal 2 or 3 of the control plug, depending on what direction is desired (current mode only). A (plus) + voltage at terminal 2 of the control plug will cause a (plus) + voltage at power terminal 1. Connect the unused terminal (2 or 3) to common.

If bidirectional control is desired (current mode only), connect the Pot between the +5V and -5V. Do not draw more than 10ma out of either supply.

4.12 Voltage feedback.

Connect the LOAD+, power terminal 3, to the VFB+ input of the control plug, terminal 6. Connect the LOAD-, power terminal 2 to the VFB- input of the control plug, terminal 5. Connect common, control plug terminal 4 to control plug terminal 3. If long runs from the **CH unit** to the load are necessary, remote sensing can be used by running a separate pair of wires from the load terminals to the VFB+ and VFB- terminals instead. Connections should be made with a shielded twisted pair with the shield connected to common at the **CH unit.** side.

4.13 Current feedback (Current loop).

Current feedback requires no connections to the VFB+ and VFB- inputs of the control plug, and should be left open. The current feedback is internal to the **CH unit.**

4.14 Disable inputs.

If the disable inputs are not to be used, connect terminals 7 and 8 to common.

Connect terminals 7 and 8 to each other and to a normally closed contact to common. An open collector transistor can be used with the collector connected to terminals 7 and 8 of the control plug.

4.15 +5V and -5V

There are two regulated supplies, separate from the internal supplies of the **CH unit** that are intended to be used for Potentiometer excitation. These supplies are short circuit proof. See Section 4.11.

4.16 Status, AOK

Terminals 11 and 12 of the control plug are connected to a normally closed relay contact that opens up if there is a problem. These terminals should be connected to the host supervisor for monitoring.

If current limit control is used, terminal 11 is the control input. It is 9vdc open circuit. This corresponds to 100% current limit. Lowering this voltage reduces the current limit value. Zero volts is approximately 0 current limit (+/-2%). The equivalent circuit is 715Ω pulled up to 9vdc.

4.17 POWER WIRING.

All power connections are made to the 4, bus bars with 1/4" holes, located below the control plug. It is recommended that the DC BUS voltage be selected so that it is 7% higher than the output voltage, and another 2 volts. The bus voltage must be less than the maximum rating of the unit.

Connect a DC supply to power terminals 1+ and 2-. Use the appropriate gauge wire, 10 ga for 30 amps, 8 ga for 40 amps, etc. If long runs are to be made, voltage drop should be calculated and compensated for in gauge and voltage level.

Connect an LC filter, (Zahn LC 225) to power terminals 3+, 2-. The LC filter then drives the load. Use the appropriate gauge wire, 10 ga for 30 amps, 8 ga for 40 amps, etc. The polarity is such that power terminal 3 will go positive (+) when a positive voltage is applied to terminal 2 (VREF+) of the control plug. The load should cause a feedback such that terminal 6 (VFB+) of the control plug is driven positive.

5.00 Specifications.

5.10 Installation Mechanical.

The mechanical dimensions of the **CH unit** are shown in Figure 5. The 12 pin control plug is on the top right side of the unit and the 3 power bus bars are below it.

**INSTALLATION DRAWING FOR
CHXXXX, CHXXXXF, CHXXXXF-SS, CHXXXXF-SSU**

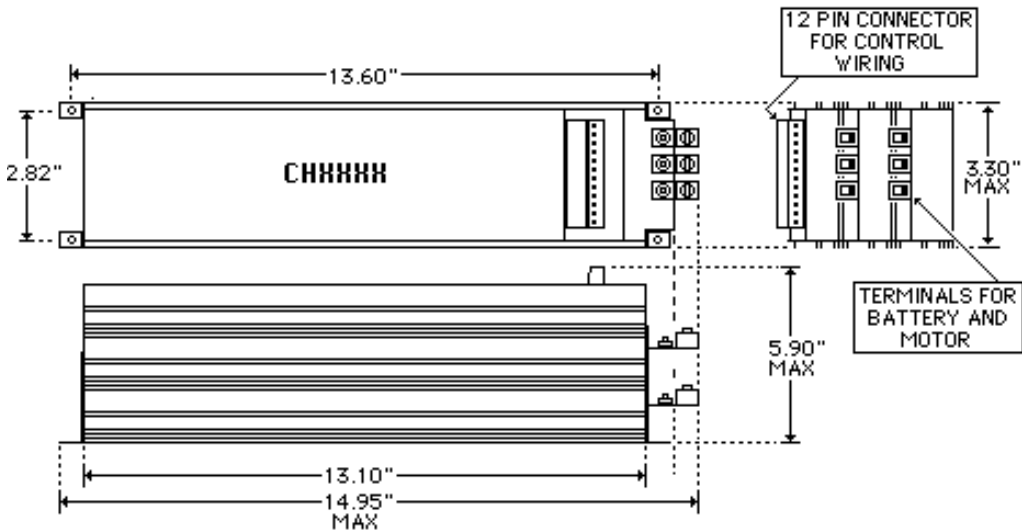

ALL TOLERANCES ARE $\pm .020$ " EXCEPT MAX DIMENSIONS.

FIGURE 5.

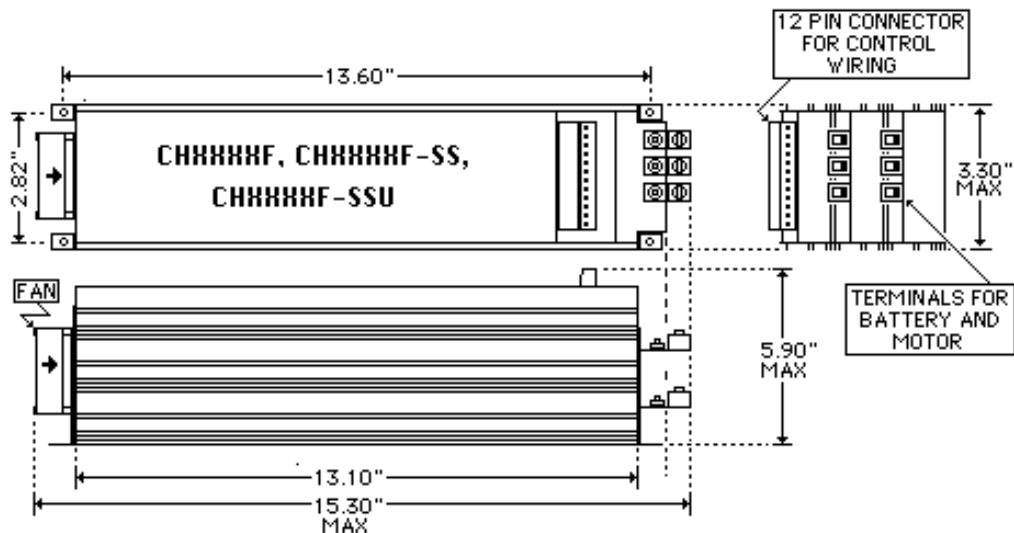

Zahn Electronics Inc. telephone: 262 835 9200
4133 Courtney St. #5 franksville, WI 53126 fax: 262 835 9201

Im218. Step Down DC/DC Converter. 1/06 Zahn Electronics, Inc. FRANKSVILLE, WI

5.20 Electrical Specifications (Control).

Input resistances.

Terminal 1 and 4 are common (control plug).

Terminal 2, VREF+: 10k ohm to common with terminal 3 tied to common. 20k ohm with respect to terminal 3.

Terminal 3, VREF-: 20k ohm to common.

Terminal 6, VFB+: 50k ohm to common with terminal 5 tied to common. 100k ohm with respect to terminal 6.

Terminal 5, VFB-: 60k ohm to common.

Terminal 7, DISABLE+: 2.2k ohm pull up to +5V or +12V, depending on selector on board.

Terminal 8, DISABLE-: 2.2k ohm pull up to +5V or +12V, depending on selector on board.

<u>Switching Frequency:</u>	31,250Hz, crystal controlled
<u>Gain Range, velocity mode:</u>	.86V to 10V for max output voltage.
<u>Gain Range, current mode:</u>	.86V to 10V for max current.
<u>Offset:</u>	Adjustable to zero with ZERO Pot.
<u>Drift:</u>	.1%/Deg C, max
<u>VFB Input voltage range:</u>	plus or minus max bus voltage.
<u>VREF input voltage range:</u>	-10 to +10 volts
<u>STATUS:</u>	NC Contact, 100 V DC, 10 Watt reed relay

5.30 Electrical Specifications (Power).

Input Voltage, DC: See Product bulletin.

(<http://zahninc.com/httpzahninc.comssloose.html>)

Output Voltage: 0 to the .94*DC Bus voltage - 2 volts

Continuous Output Current: See Product bulletin.

(<http://zahninc.com/httpzahninc.comssloose.html>)

5.40 Operational Modes.

1. Voltage Loop, without IR Compensation.
2. Voltage Loop, with IR Compensation.
3. Current Loop.

5.50 Status

The Status of the **CH unit** is conveyed by a normally closed contact available at terminals 11 and 12 of the control plug. The Status is also referred to as fault and "AOK". The red LED turns on and the contacts are opened if:

1. There is no power to the unit.
2. The internal power supplies have failed.
3. The **CH unit** is in thermal limiting.

6.00 Setup Instructions.

6.10 Setup for Voltage Loop.

Review all the Adjustments, section 3.0. If this is a new installation, set the VLP TIME CONSTANT digital switch at "9", and the VLP AC GAIN at "0" to sandbag the loop. Otherwise these values are known and should be set accordingly.

Connect the wires to the control and power plug. With the load disconnected, turn power on and measure the output voltage. It should be set to desired value. The green light should be on.

Remove the wires to terminals 7 and 8. The output should go to zero. Remove power and restore the wires, permanently to terminals 7 and 8.

[For variable output only.] Set VREF to 0 which corresponds to zero output. Turn on power and adjust the ZERO pot for zero volts out.

Set VREF to its maximum value. Set the GAIN pot for desired output voltage.

Adjust the VLP TIME CONSTANT and VLP AC GAIN digital rotary switches for desired response.

With a unit step load change, either full or partial load, monitor the output voltage. Adjust the VLP AC GAIN rotary switch for the number and/or height of overshoots. Adjust the VLP TIME CONSTANT for response time.

The current loop has a similar adjustment located under the top cover of the **CH unit**. This is normally set at the factory and should not need to be adjusted.

6.20 Setup for Controlling Current Limit.

SETUP FOR CONTROLLING CURRENT LIMIT
THROUGH PIN 11 AT THE 12 PIN CONTROL PLUG

1. With power off, remove the 2 screws securing the top cover of the unit.
2. Look for SW13 and set the switches as shown below.

Turn switch # 1 on, (COM).
Turn switch # 2 off, (REL).
Turn switch # 3 on, (9V).
Turn switch # 4 off, (VIR).

C	R		V
O	E	9	I
M	L	V	R

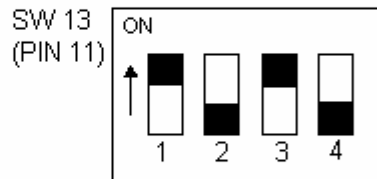

3. After switches have been set, put cover back on, making sure that the back edge of the cover hooks onto the back edge of the unit, then secure with the 2 screws.
4. Now you can connect a resistor from PIN 11 to COM, a 620 ohm 1/4 watt resistor for example, will give you about 1/2 of the total current limit that is set internally at the factory. If pin 11 is left open, (which is 9VDC open circuit) you will get maximum current limit set by the factory. Lowering this voltage reduces the current limit value. Zero volts is approximately 0 current limit (+/- 2 %). Zero volts, pin 11 to COM, must sink 13ma DC.