

Rev A

**TABLE OF CONTENTS, CCH40050-SSU-1Q DC/DC CONVERTERS**

<b>SECTION</b>	<b>TITLE</b>	<b>PAGE</b>
1.00	Introduction and Description.....	2
	FIGURE 1 .....	3
2.00	Theory of Operation.....	4
3.00	Adjustments.....	6
4.00	Wiring Instructions.....	7
4.10	CONTROL WIRING.....	7
4.11	INPUT COMMAND REFERENCE.....	8
4.12	VOLTAGE FEEDBACK.....	8
4.13	CURRENT FEEDBACK (Current Loop).....	8
4.14	DISABLE INPUT.....	8
4.15	+5V AND -12V.....	8
4.16	FAULT.....	8
4.17	POWER WIRING.....	9
	Figure 3. Mechanical Installation.....	10
5.00	Specifications.....	11
5.10	INSTALLATION MECHANICAL.....	11
5.20	ELECTRICAL SPECIFICATIONS (Control).....	11
5.30	ELECTRICAL SPECIFICATIONS (Power).....	11
5.40	INPUT AND OUTPUT CURRENTS .....	12
6.00	Setup Instructions.....	12
6.10	SETUP FOR VOLTAGE LOOP.....	12

## 1.0 Introduction and Description

The CCH40050-SSU-1Q is a high performance 1 quadrant, crystal controlled, Double Half H Bridge, Interlaced, boost converter, which require two external inductors. It is a compact, self contained unit with its own power supply. It is based on the HC08 microcomputer technology. Power to the unit is from a DC supply, Such as a battery, Solar panels, or a fuel cell. To date, the only offering is a subpanel version, where two inductors, and a large power terminal block, are mounted and wired to a subpanel.

The switching frequency is exactly 31,250Hz. Interlacing lowers input and output voltage and current ripple. At a 2:1 boost (IE 165 to 330 volts), the ripple at the input and output is zero.

The input voltage and the output voltage share a power common. Therefore, there is no isolation between the power input and the power output. The input power source (battery) shares its power common with the load power common.

The Control signals, which are inputs and outputs, **are** isolated from the power circuit. So the signal common should be tied to the appropriate point.

The output voltage, B+, is controlled by a 0 to 5v differential input voltage. The input current limit is controlled by a 0 to 5v voltage. There is a +5v supply available for external circuitry, a disable input, and enable output, an analog output that can show signals inside the microcomputer, and a fault output.

The internal temperature of the CCH unit is monitored and in the event of an excessively high ambient temperature, input current, and thus current to the load is reduced automatically to hold the transistor temperatures to a safe level. A corresponding red LED turns on, a fault signal is generated. The input current is not "turned off", but reduced to hold the temperature.

A -12v supply is available through a 10k resistor.

BLOCK DIAGRAM FOR 330V DC TO DC CONVERTER  
ZAHN ELECTRONICS INC.

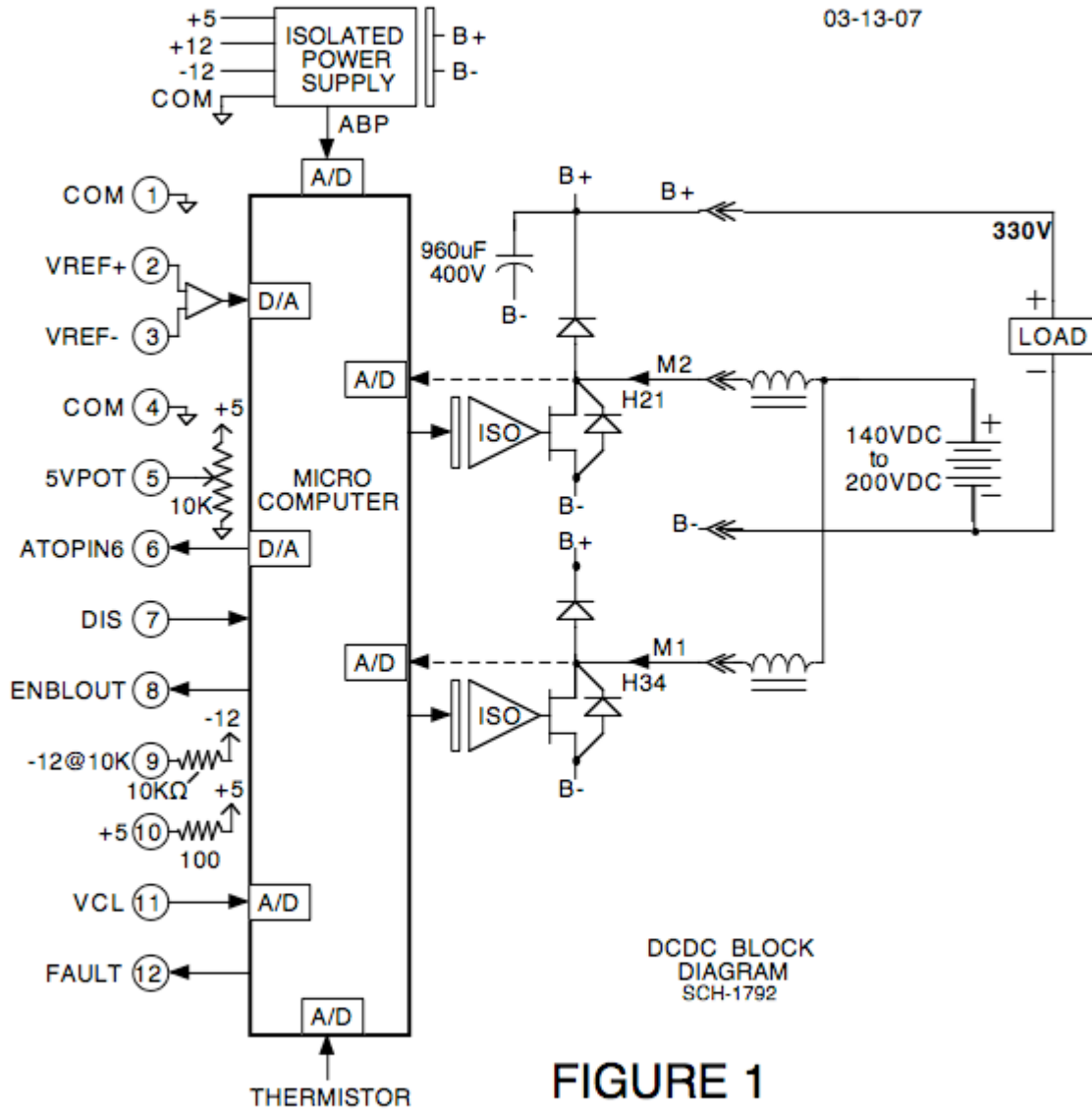

## 2.0 Theory of Operation

Block Diagram.  
Refer to Figure 1.

The power source, IE, a battery, is connected to terminals M1 and M2, through inductors. For a CCH40050-SSU-1Q, a 400uHy inductor is connected between M1 and the source. Another 400uHy inductor is connected to M2 and the source. Source current is sensed by hall sensors, depicted as H21, and H43, and is sent to the microcomputer. These sensors are isolated. The microcomputer digitizes these signals. The output drives the load, IE a battery, which is connected to B+ and B-. A REDLED and a GRNLED indicate status.

The voltages at M1 and M2 are PWM (pulse width modulation) signals. When the output at M1 or M2 is high, it is very close to B+. When the output is low, it is very close to B-. The duty cycle varies to control the output voltage and the input current. These outputs at M1 and M2 are “interlaced”. This means that at small duty cycles, the voltage at M2 starts before the voltage at M1. At a 50% duty cycle, the voltages at M1, M2, are square waves, out of phase, so the input and output current and voltage ripples are zero. At duty cycles greater than 50%, the voltages at M1, M2, overlap.

An isolated power supply receives its power from B+ and B-. It supplies the circuit with +5,+12,-12, volts, and an isolated signal, “ABP”, which is the B+ voltage. ABP means Analog B plus. This signal is used to close the voltage loop. Thus the VREF+, VREF- inputs control ABP.

The “5VPOT” is the only adjustment. It was included on the pc board for customer convenience. It is a 10k pot with +5Vdc across it. It can be used for controlling VREF+, VREF-, which would set the B+ voltage, or it can be used to drive the “VCL” input.

The “ATOPIN6” output is an analog signal which will monitor the microcomputer internal signals.

The “ENBLOUT” output indicates when the system is enabled.

The “DIS” input disables the output. When “DIS” is a logic 1, (5V logic), all the FETs are off. When the “DIS” input is switched back to a “0”, the system is rearmed, with a soft start. The “DIS” input will reset the overvoltage fault at B+, B-, if the voltage at B+, B- is less than the overvoltage fault voltage.

A negative source, -12V, is available at pin 9 of the control terminals. This can be used for powering external circuitry.

The “VCL” input, pin 11, controls the input current limit of the input current coming in from M1, and M2. Zero volts is zero current limit.

The “FAULT” output becomes a logic 1 when there is a fault, such as an overvoltage or overtemperature. The RED LED comes on with the FAULT signal. If the fault is set from overvoltage, the fault is removed if the voltage at B+, B- goes to  $\frac{3}{4}$  of the overvoltage specification.

The GRN LED comes on when the B+, B- terminals reach 125 volts.

In normal operation, the B+ terminal will always be greater than the average value of the M1, M2 inputs. There is a diode from M1 and B+, and a diode from M2 to B+. These diodes will supply voltage to B+, through M1 or M2, even if the input at VREF+, VREF-, is set lower than the feedback, ABP, which follows B+. In other words, the unit can be turned on by applying a voltage to B+, or through inductors to M1 or M2. Note that a diode between B+ and the load will not allow turn on from the load.

The switching frequency of the PWM is exactly 31,250 Hz, which has a period of 32.000 usec.

A 70 degree centigrade PTC thermistor, close to the power MOSFETs, is sensed. If the temperature reaches 70C, the current limit is reduced accordingly, the red LED is turned on, the enable signal goes to zero, and the RED LED is turned on. This would be like lowering the VCL signal. The current is reduced to hold the temperature at 70C.

### 3.0 Adjustments

There are no adjustments. The “5vpot” is considered a customer adjustment. The “5vpot” is a 10k pot with +5v across it that can be used to control VREF+,VREF-, as an output voltage control, or the pot can be used to control the input current limit value, ACL.

There is an internal voltage loop that has VREF+,VREF- as a reference, and ABP as a feedback. This voltage loop has a KP and a KI. These are fixed internally.

There is an internal current loop that has the output of the vloop as a reference, and the H21, H43 signals as a feedback. The current loop has a KP and a KI. These are fixed internally. The ACL input controls the current limit value of this loop. The current limit value, ACL, clamps the output of the vloop, which is the reference of the current loop.



**Email** 4133 Courtney St. #5 Telephone: 262 835 9200  
**ZAHN** Franksville, WI 53126 Fax: 262 835 9201  
 Email: zahn@zahninc.com Website: zahninc.com

3-07

INSTALLATION WIRING  
 Step Up Voltage Regulator.

DCDC170/330/7000?

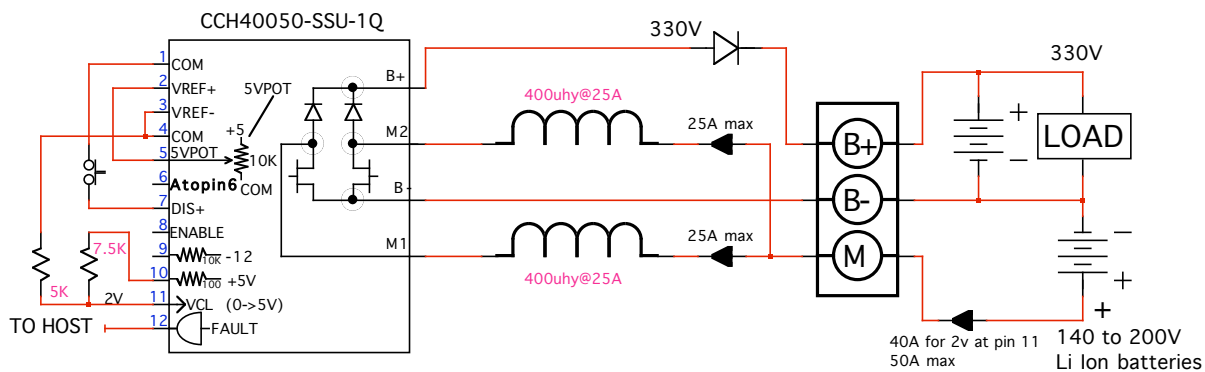

- NOTES:
- 1 WIRE DISABLE INPUT, PIN 7, TO NC CONTACT.
  - 2 SELECTING CERTAIN SWITCHES ON TOP BOARD OF CCH UNIT ALLOWS ANY OF 16 ANALOG SIGNALS AT PIN 6.
  - 3 VCL, PIN 11, SETS THE CURRENT LIMIT LEVEL OF THE LI batteries.

succh003

## FIGURE 2

### 4.00 Wiring Instructions.

See Figure 2.

#### 4.10 Control Wiring.

The Control wiring consists of connecting low current carrying wires to the 12 terminal control plug located on the top right side of the unit. 22 gauge wire is adequate for all connections.

#### 4.11 Input command reference.

Refer to Figure 2. The input command reference, VREF+ and VREF-, is the input signal that controls the load voltage at B+,B-. If the reference is a single ended signal, VREF-, terminal 3 of the control plug, should be tied to common. VREF+ should be tied to the signal source and the signal source common should be tied to terminal 1 or 4 of the control plug, which is the converter common. VREF+, in this case will swing 0 to a positive DC value.

If a Pot is used for controlling the load voltage or as a stand alone system, the 5VPOT signal or an external pot can be used. The input to VREF+ minus VREF-, should swing from 0 to 5V. This input should not exceed the +5 available at pin 10.

#### 4.12 Voltage feedback.

The voltage feedback from B+,B- is internal. No wiring is necessary.

#### 4.13 Current feedback (Current loop).

The input current feedback is sensed with isolated hall sensors and is internal. No wiring is necessary.

#### 4.14 Disable input.

If the disable input is not to be used, connect terminal 7 to common.

If the Disable input is to inhibit the CCH unit, connect terminal 7 to a normally closed contact to common. An open collector transistor can be used with the collector connected to terminal 7 of the control plug.

#### 4.15 +5V and -12V

There are two regulated supplies, that can be used for external circuitry. The +5V at pin 10 is internally connected to the +5V used for the CCH unit through a 100 ohm resistor. Similarly, the -12V internal supply is available at pin 9 and is connected to the internal -12V supply through a 10k ohm resistor.

#### 4.16 Fault

Pin 12 of the control plug is connected to the internal microcomputer that switches to a "1" if there is a Fault. This pin should be connected to the host supervisor for monitoring.

#### 4.17 POWER WIRING.

All power connections are made to the 4, copper bus bars, located below the control plug.

Connect a DC supply to power terminals M1 and M2 through inductors. Use the appropriate gauge wire. If long runs are to be made, voltage drop should be calculated and compensated for in gauge and voltage level.

Connect the load to terminals B+ and B-. Use the appropriate gauge wire.

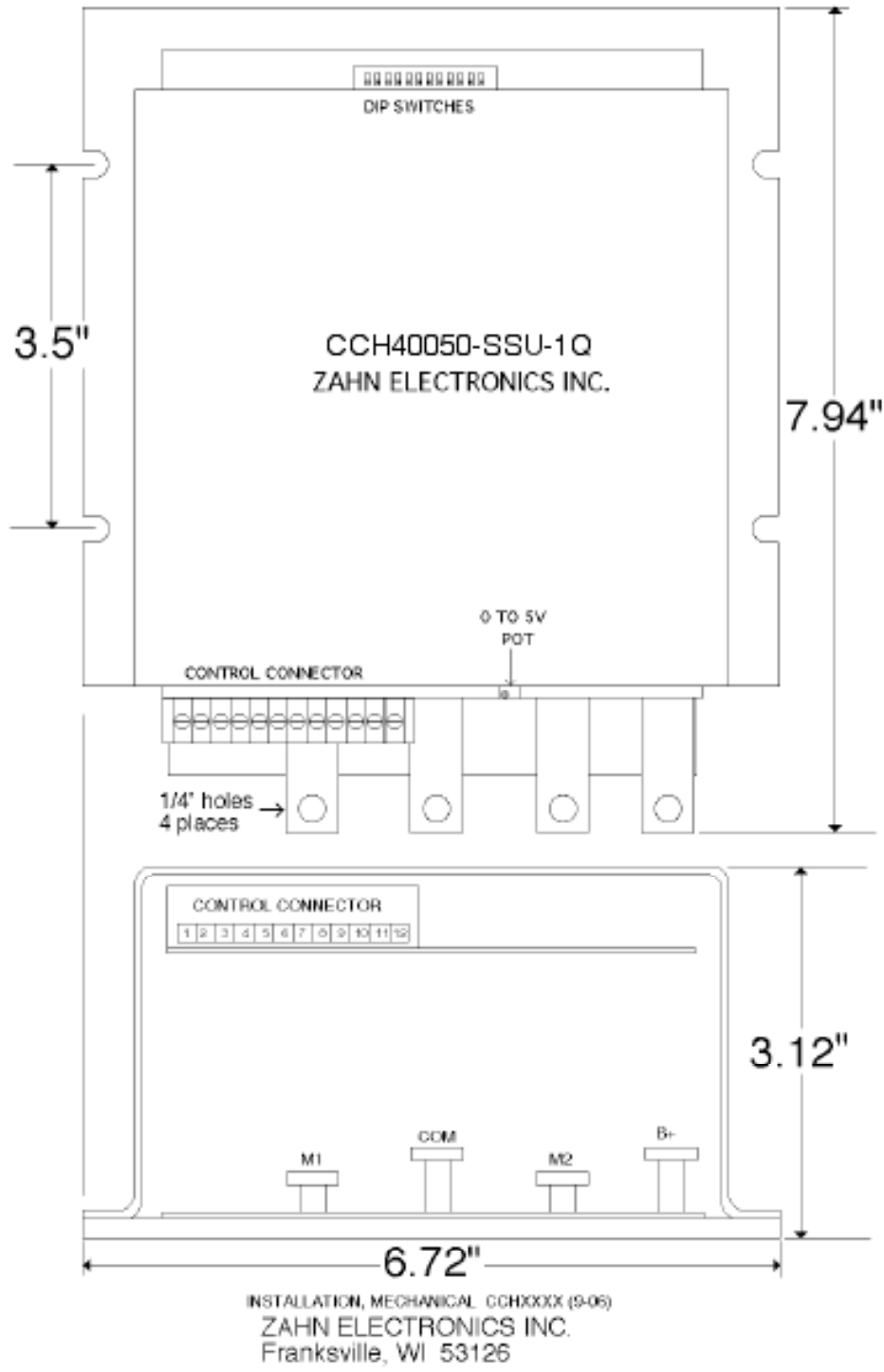

Figure 3.

## 5.00 Specifications.

### 5.10 Mechanical Installation.

The mechanical dimensions of the CCHXXXX-SSU are shown in Figure 3. The Bus bars have 1/4" holes. The 12 pin control plug is on the top left side of the unit and the 4 bus bars are below it.

### 5.20 Electrical Specifications (Control). See Figure 2.

#### Input resistances.

Terminal 1 and 4 are common (control plug).

Terminal 2, VREF+ input: 4.99k ohm to common.

9.98k ohm with respect to terminal 3.

Terminal 3, VREF- input: 9.98k ohm to common.

Terminal 5, 5VPOT output: Wiper of a 10KΩ pot. 0 to +5V.

Terminal 6, ATOPIN6 output: 1uf, 1kΩ RC filter. RC filter is PWM driven from Microcomputer at 32usec period.

Terminal 7, DIS input: 4.99k ohm pull up to +5V. Turns off all FETs when a "1". CCH unit will soft start when switched to "0".

Terminal 8, ENBLOUT output: 4.99k ohm pull up to +5V. ENBLOUT is low if DIS is hi or overtemperature.

Terminal 9, "-12at10K" output: 10KΩ to -12V.

Terminal 10, +5 output: Terminal 10 is connected thru 100Ω to +5V.

Terminal 11, VCL input: 0 to +5V that controls input current limit.

0->0 current limit, +2.5V-> Nameplate current.

Terminal 12, FAULT output: "0"-> no fault. "1"-> overvoltage at B+, or temperature sensor exceeds 70 degrees Centigrade.

Overvoltage fault is reset if overvoltage drops to ¾ of overvoltage specification, or if the unit is disabled with the B+,B- voltage under the overvoltage specification.

Switching Frequency: 31,250Hz, crystal controlled

Voltage Gain: +5V at VREF+ will cause max nameplate voltage.

Resolution: 5V->255 LSB

Current Limit Gain: 2.5V at ACL input will cause max nameplate current.

Resolution: 2.5V->127 LSB

### 5.30 Electrical Specifications (Power)

Input Voltage, DC: CCH40050-SSU-1Q 140 to 200V

Output Voltage, B+, B-, DC: CCH40050-SSU-1Q 330V

Example: A CCH100210-SSU-1Q has an input voltage of 140 to 200 volts. The output voltage is set at 330 volts. The output voltage at least 130v greater than the input voltage.

Continuous Input Current: (internally limited) 50adc. Note that pin 11 controls this. 2vdc at pin 11 would program the current limit to 40adc.

Continuous Output Current: (maximum allowed)

The continuous Output current must be calculated. It depends on,  $V_{in}$ ,  $I_{in}$ ,  $V_{out}$ , and the efficiency of the unit.

$$I_{out(max)} = (V_{in} * I_{in} * Efficiency) / V_{out} = P_{out} / V_{out}$$

Example: With  $V_{in}=165v$ ,  $I_{in}=40A$ ,  $V_{out}=330v$ ,  $Efficiency=.98$ ,

$$I_{out(max)} = (165 * 40 * .98) / 330 = 19.6A, \text{ where } P_{out} \text{ is } 6468 \text{ Watts.}$$

#### 5.40 Operational Modes.

1. Voltage Loop, with input current limit, One quadrant.

## 6.00 Setup Instructions.

### 6.10 Setup for Voltage Loop.

Connect the wires to the control and power plug. With the load disconnected, turn power on and measure the output voltage. It should be set to desired value. The green light should be on.

Remove the wire to terminal 7. The output should drop to the input voltage. Remove power and restore the wire, permanently to terminal 7.

With a unit step load change, either full or partial load, monitor the output voltage. The output should follow with a maximum of one overshoot.