



# ZAHN ELECTRONICS, INC.

EEmail  
ZAHN

4133 Courtney St. #5  
Franksville, WI 53126

Telephone: 262 835 9200  
Fax: 262 835 9201

Email: zahn@zahninc.com

Website: zahninc.com

## INSTALLATION WIRING, 5000 Watt DC TO AC INVERTER

12-06

THE FUEL CELL HAS A VARYING VOLTAGE OF 27 TO 63 VDC AND PUTS OUT 5435 WATTS DRIVING TWO DCAC45/120/2500 UNITS THAT PUT OUT 120/240VAC, 5000 WATTS. THE LEFT UNIT SYNCHRONIZES THE RIGHT UNIT, WITH THE SOUT TO SIN CONNECTION, SO THAT THE RIGHT UNIT SINE WAVE OUTPUT IS 90 DEGREES LAGGING THE LEFT UNIT. BOTH UNITS PUT OUT 2500 WATTS, EACH. THE FUEL CELL CURRENT IS PURE DC WITH EQUAL LOAD CURRENTS.

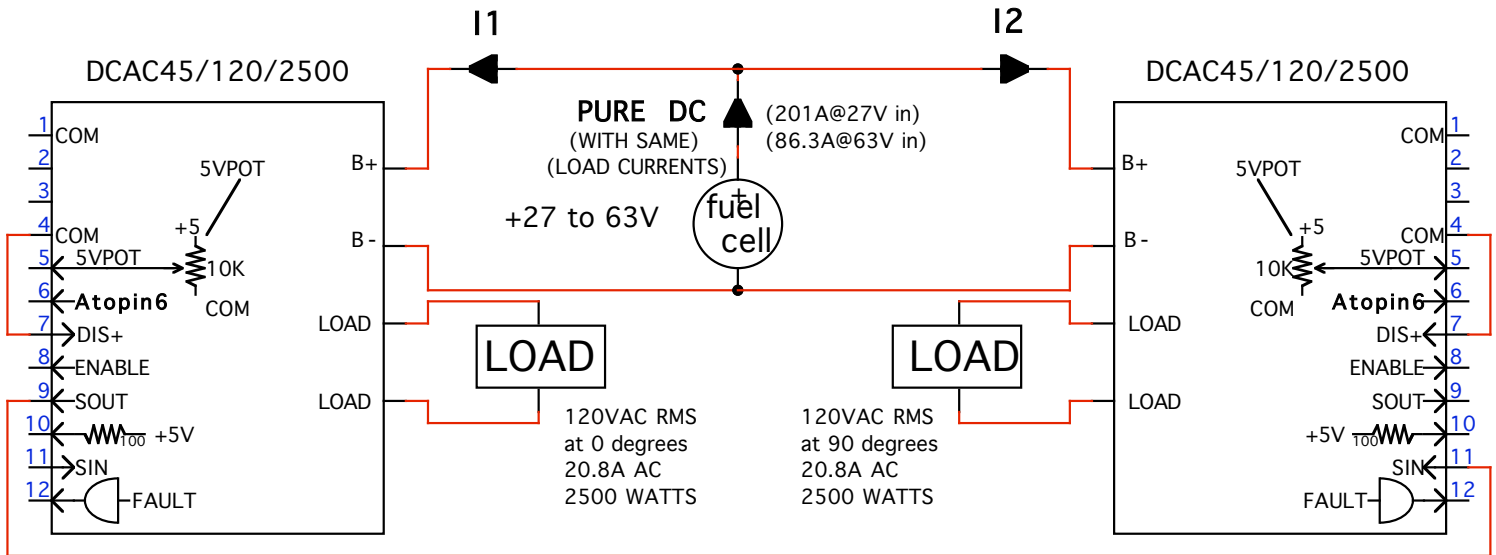
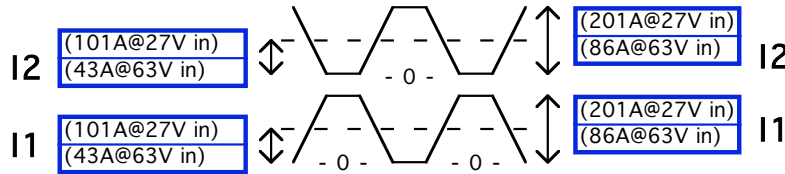

NOTES:  
1 WIRE DISABLE INPUT, PIN 7, TO NC CONTACT.