

INSTALLATION WIRING, 30KW, DC TO 3 Phase AC INVERTER

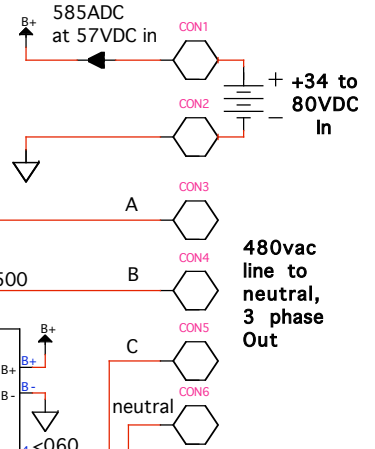

480vac line to neutral, 3 phase Out

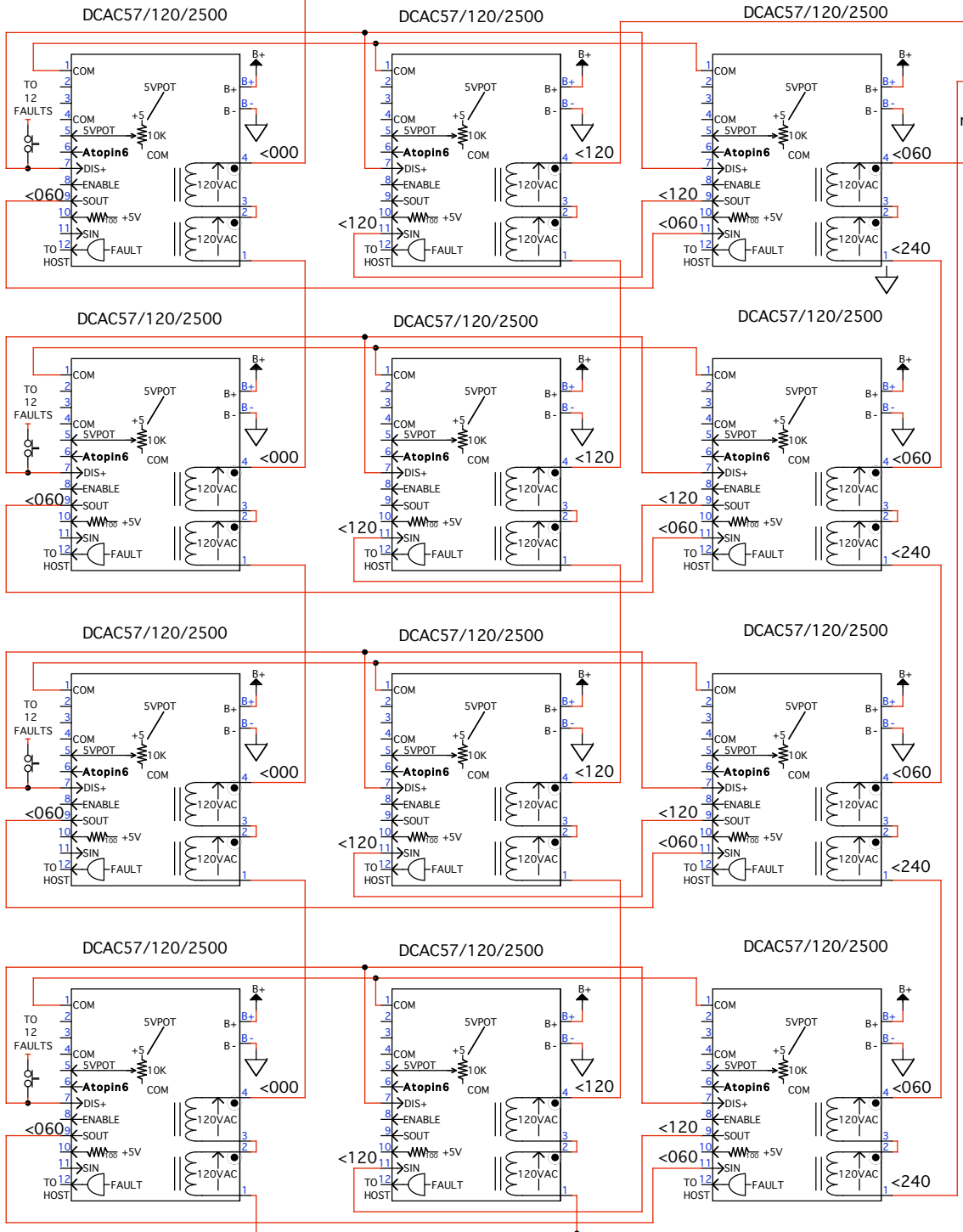

NOTES:

- 1 WIRE DISABLE INPUT, PIN 7, TO NC CONTACT.
- 2 SELECTING CERTAIN SWITCHES ON TOP BOARD OF CCH UNIT ALLOWS ANY OF 16 ANALOG SIGNALS AT PIN 6.

3	PTE6	PTE7	SOUT WITH RESPECT TO SIN	PTE6 SWITCH	PTE7 SWITCH
1	1	0	0 DEGREES	OFF	OFF
1	0	0	60 DEGREES	OFF	ON
0	X	0	90 DEGREES, X means don't care	ON	X

ALL UNITS

- 4 THE DIS+ SWITCH IS CONNECTED TO 12 FAULTS. THIS IS EACH FAULT OUTPUT, NANDED.

dca00X