

ZAHN ELECTRONICS, INC.

E Mail
ZAHN

4133 Courtney St. #5
Franksville, WI 53126

Telephone: 262 835 9200
Fax: 262 835 9201

Email: zahn@zahninc.com

Website: zahninc.com

INSTALLATION WIRING

10-08

FUEL CELL TO 24V STEP UP DC/DC CONVERTER.

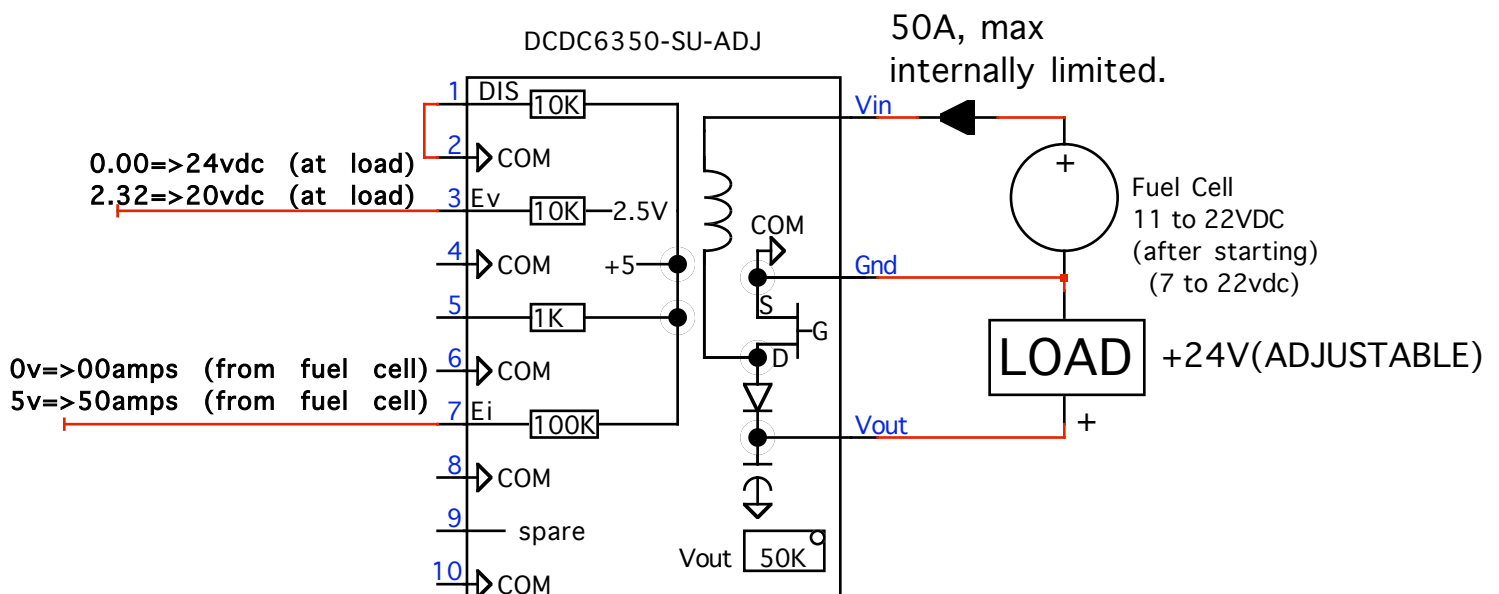

NOTES:

- 1 Adjust the onboard 50K Ω pot for 24vdc at the load. Ev= 0 .
- 2 Ev control from host. Ev controls the output voltage.
- 3 Ei control from host. Ei controls the input current limit.
- 4 DIS, disable input will disable converter. Disabling the converter makes the output voltage, Vout, equal to the input voltage, Vin. Follow the input current thru the inductor, (the inductor is a short since there is no switching), thru the diode to Vout. (the FET is off)